



STARLINE S.p.A.
Via F. Baracca, 30
24060 S. PAOLO D'ARGON
(Bergamo) ITALY
Tel. 035/958041-958102
Fax 035/958413
http: www.starline.it
e-mail: starline@starline.it

QUALITY MANAGEMENT SYSTEM :



MANUAL INSTRUCTION N° 124-4/98 FOR STORAGE, INSTALLATION, OPERATION AND MAINTENANCE FOR STARLINE BALL VALVES TYPES METAL TO METAL N°4

REFERENCE: STARLINE CATALOGUE Q.A.M. AND PURCHASE ORDER

N. 4 METAL TO METAL

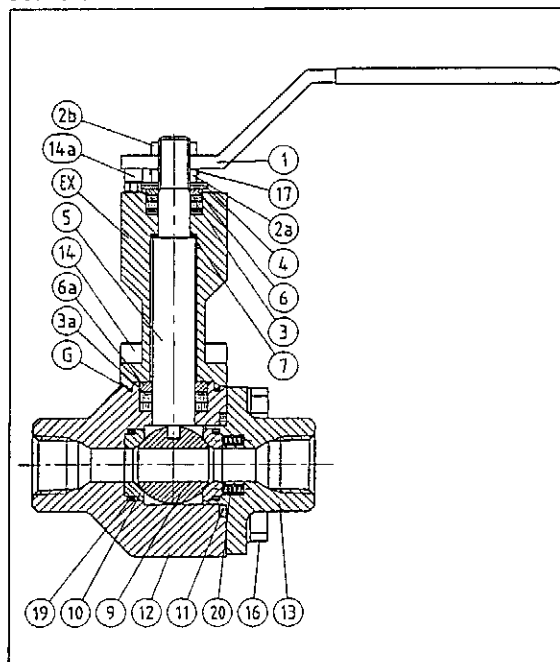

ITEM n°	Q.TY n°	PART NAME
NP	1	NAME PLATE
G	1	EXTENTION GASKET
EX	1	EXTENTION
1	1	HANDLE
** 2a	1	HANDLE NUT
** 2b	1	LUCK NUT
* 3	3	PACKING RING
* 3a	2	PACKING RING BODY
** 4	2	SPRING WASHER
5	1	STEM
** 6	1	GLAND PACKING
** 6a	1	GLAND PACKING BODY
* 7	1	THRUST WASHER
9	1	BALL
10	2	SEATS
* 11	1	BODY GASKET
12	1	BODY
13	1	END CONNECTION
14	4	EXTENTION SCREW
14a	1	STOP PIN
16	note 3	BOLTS
** 17	1	STOP WASHER
* 19	2	SEAT SEAL
20	4	SEAT SPRING

TABLE WITH TIGHTNESS VALUES FOR HANDLE NUT 2a - 2b AND BODY BOLTS

VALVE SIZE	HANDLE NUT n° 2a / LOCK NUT n° 2b		BODY BOLTS n° 16			EXTENTION SCREWS n° 14			NOTE	
	Dimension	Nm	Inch Lbs	Dimension	Nm	Inch Lbs	Dimension	Nm		Inch Lbs
1/4"	M12x1.25	15	130	M8x17	35	310	M8x16	35	110	
3/8"	M12x1.25	15	130	M8x17	35	310	M8x16	35	110	
1/2"	M12x1.25	15	130	M8x17	35	310	M8x16	35	110	
3/4"	M12x1.25	15	130	M10x22	50	440	M8x16	35	110	
1"	M15x1.5	25	220	M10x22	50	440	M8x16	35	110	
1.1/4"	M22x1.5	40	355	M12x30	70	620	M10x22	50	440	
1.1/2"	M22x1.5	40	355	M12x30	70	620	M10x22	50	440	1
2"	M22x1.5	40	355	M12x30	70	620	M10x22	50	440	2

Note :

- * FOR START-UP OR COMMISSIONING SUGGESTED 5% OF Q.TY
- * SUGGESTED MATERIAL AFTER TWO YEARS SERVICE
- ** SUGGESTED MATERIAL AFTER FIVE YEARS SERVICE
- 1) FOR CLASS 300+600 LBS GEAR OPERATED
- 2) GEAR OPERATED
- 3) FOR SIZE 1/2" to 1.1/2" n° 4 BOLTS - FOR SIZE 2" n° 6 BOLTS

1.0 SCOPE

This manual is intended as a guide to assist customers or end-users for storage, installation, and maintenance of Starline ball valves in the standard arrangements. For this reason subsequent additions and special instruction to the present manual will be provided in case of special ball valve, critical services or customer requirements.

2.0 APPLICABILITY

This manual is applicable to Starline ball valves.

3.0 STORAGE

3.1 INFORMATION ON SURFACE PROTECTION (EXTERNAL/INTERNAL) AND PACKING DETAILS.

- a- before shipment from Starline factory all c.s. valves (A105-LF2) are protected against corrosion by phosphated treatment.
- b- all S.S. valves (304-316-F51-F44-F321 etc.) are pickled and passivated
- c- a pure vaseline oil is used as lubricant on all internal surfaces, this may be removed with a solvent if found objectionable. All valves are adequately packed into a strong cardboard case in such a way to avoid any possible damage during transport and storage period before use.

3.2 CAUTION AND MAINTENANCE PERIOD

3.3 IF BALL VALVES ARE NOT DESTINATED FOR IMMEDIATE USE FOLLOWING CAUTIONS MUST BE TAKEN:

- a- if possible it would be advisable to leave the ball valves in their own packing cases during the entire period of storage.
- b- ball valve must remain in open position during all this time
- c- in order to prevent any damage, the protective plastic cover on the ends of the valves shall not be removed.

3.4 ATMOSPHERIC PROTECTION

- a- it is advisable to store the valve in waterproof conditions in a building with an adequate roof. Ball valves shall be protected to safeguard against all the environments: humidity, moisture, rain, dust, dirt, sand, mud, salt air, salt spray and seawater.
- b- all valves complete with actuators are to be stored in closed and dry conditions.

3.5 LONG STORAGE PERIOD

Valves to be stored for a long time shall be checked by the quality control personnel every 6 months; every 3 months when valves are actuated.

3.6 MAINTENANCE DURING STORAGE PERIOD

- a- internal surface must be inspected to check complete dust or other foreign parts absence
- b- old rust or any dust must be removed by wiping with proper solvent
- c- after cleaning, ball valves must be lubricated by using an adequate lubricant
- d- ball valves must be operated for at least 2 complete cycles

4.0 INSTALLATION

4.1 THE BALL VALVES MAY BE INSTALLED IN ANY POSITION USING A STANDARD PIPE FITTING PRACTICES

4.2 INFORMATION AND CAUTION BEFORE INSTALLATION OF THE VALVE

- a- pipe must be free of tension
- b- pipe must be flushed to clean the dirt, burrs, calamines, welding residues etc. which would damage ball and seats
- c- the valve must be kept in OPEN POSITION during installation and protective plastic cover must be removed only at the moment of installation
- d- at the moment of the shipment the ball is lubricated with a pure vaseline oil, which can be easily removed with a solvent if required
- e- ball valves normally have a space between ball and inside cavity of the body which could trap the product, care should be taken to drain the cavity.
- f- care should always be taken to install the automated ball valves. Check for a correct actuator rotation and well done electrical connection

4.3 INSTALLATION OF THREADED ENDS

Use conventional sealant such as hemp core, ptfе etc

4.4 INSTALLATION OF WELDED ENDS BALL VALVES

SW - BW instructions for welding the valves on the line: with valve in open position tack weld in four points on both ends and then complete the welding without dismantling the valve and control for easy operation

4.6 INSTALLATION OF FLANGED ENDS

Easy fitting on the line with the adequate bolts, nuts and gaskets.

5.0 OPERATION

CAUTION! during the operation the ball valves must be in either complete OPEN or CLOSED position in order to ensure their smooth and efficient working and long duration of seats. Leaving the ball in half open position could eventually cause damage to the metal coating.

5.1 MANUAL OPERATION

The opening and closing of the valve is done by turning the handle a quarter turn (90°)

a- valve is in open position when the handle is in line with the valve and pipe line

b- valve is in closed position when the handle is across the pipe line

5.2 AUTOMATED OPERATION

Valve can be automatically operated by: A pneumatic actuators (DA or SR), B hydraulic actuators, C electrical actuators, D gear box (manually operated). In this case no stop is fitted on the valve since it is normally a part of the actuators.

6.0 MAINTENANCE

CAUTION! Before starting the maintenance be sure that all pressure on the pipe is relieved.

- open and close the ball valve at least once to release the pressure completely also from the valve body.

- the ball valves if correctly used, normally do not need any internal lubrication and maintenance. However, when necessary, ball, or seats can be replaced only by relatively qualified personnel following the instruction of the manual without needs to use any machinery.

- for further information about the recommended SPARE PARTS LIST please check drawing, catalogue or contact the factory.

6.1 STEAM LEAKAGE

If leakage is evident on stem packing area, it can be eliminated by increasing the tightness of the lock nut 2b. In case leakage is still persisting the replacement of the stem packing 3 is recommended. For handle nut and lock nut (2a-2b) tightness see table.

6.2 BODY SEALS LEAKAGE

Check for the tightness of the body bolts 16 according to table in case it is still leaking, it is necessary to replace the body seals 11.

6.3 IN LINE OR SEATS LEAKAGE

Check that valve is in fully closed position if so and the leakage is persisting the valve must be disassembled to replace damaged parts.

6.4 SAFETY PRECAUTION BEFORE REMOVING THE BALL VALVE FROM THE LINE FOR DISASSEMBLE

a- check that all pressure is exhausted from the line (upstream and downstream) and half open the ball to ensure that no pressure is trapped in the body cavity. In other words it must be drained of all fluid/gas and pressure.

b- remove the valve from the line and cycle valve at minimum 1 full cycle to ensure that any pressure trapped is released

c- **CAUTION!** If the fluid in the line and into the valve is toxic, inflammable, corrosive or damaging for any other reason, it is advisable to take following precaution during the valve repairing:

- use protective eye mask or glasses

- use gloves, overalls and suitable footwear

- ensure that running water and fire extinguisher is easily available at any moment

7.0 VALVE DISASSEMBLY TO INSPECT AND/OR REPLACE BODY SEALS, SEATS, PACKING AND BALL

a- set the valve in open position and take out all body bolts 16 and complete body from end connections

b- close the ball and remove seats 10, seat seals 19, ball 9 and body seals 11, be careful not to damage the ball

c- remove handle nut 2a, handle 1, stop washer 17, lock nut 2b, spring washer 4, gland packing 6

d- take out all extension screws 14, remove extension EX, push the stem 5. Remove packing rings 3 from extension and thrust washer 7 from stem.

e- remove gland packing 6a, packing rings 3a and extension gasket G from body

8.0 INSPECTION AND REPLACEMENT

With the valve completely disassembled, clean and examine all the following components:

a- surface of the ball and seats: any surface defect, particularly in the sealing area will be extremely detrimental to the performance of the valve and therefore the ball or seats should be replaced if found defective

b- seat seals: replacement of seat seals is recommended

c- stem seals, extension seal and body seal: also to be discarded and replaced by a new one

d- remaining components of the valve: after cleaning it is required a careful examination for wear, corrosion and mechanical damages particularly on threaded components. If components are found defective they should be replaced

9.0 RE-ASSEMBLY

Clean inside of body and stem housing. A light oil/grease compatible with line fluid can be used on ball, seats and stem surfaces.

9.1 STEM AND EXTENSION RE-ASSEMBLY

a- replace thrust washer 7 and then insert the stem from inside extension

b- install the packing ring 3, gland packing 6, spring washer 4 and lock nut 2b and tighten. To avoid rotation of stem, apply temporarily the handle install stop washer 17, handle 1, handle nut 2a and tighten (see values given in the table)

c- install the packing ring 3a, gland packing 6a, extension gasket G and fix extension EX on body

9.2 BALL, SEATS AND SEALS RE-ASSEMBLY

a- place the stem in closed position, insert the body gasket 11, seat seal 19, seat 10 and ball in the same position inside body

b- insert the seat springs 20, seat seal 19 and seat 10 inside end connection

c- rotated the stem in open position

d- put the body on the end connection and tighten bolts firmly (see values given in table)

10.0 TESTING

a- after having completed the re-assembly check for the maneuverability of the valve and make sure that ball rotates freely

b- if facilities are available, test the ball valve to the appropriate specification

11.0 AUTOMATED BALL VALVES

a- if the valve is automated, reinstall the actuators and please note that the handle is not used. If necessary, reset the stops. First set the valve in open position and check that ball is fully open. Second set the valve in closed position and check, adjusting if necessary, for the best closure.

b- **CAUTION!** Valves with electrical actuators should be tested starting from valve in: HALF OPEN - HALF CLOSED POSITION. This is to ensure that electrical connection is all right and rotation is correct. In case of wrong position switch off electrical actuators immediately and change the direction. Limit and torque switches are ineffective if rotation is wrong.