

Instruction Manual

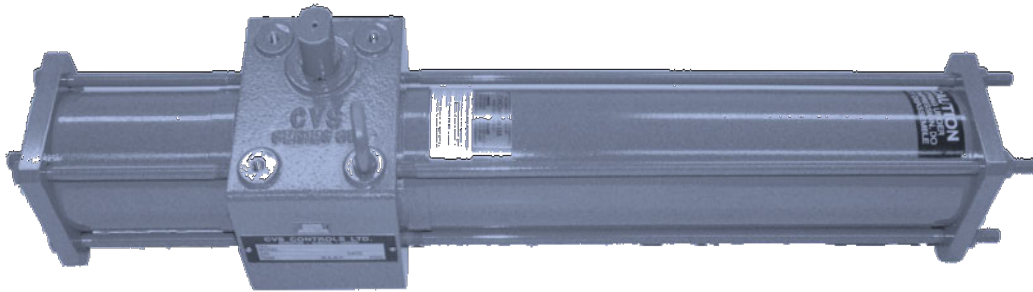

Figure 1: CVS Series 35 SRM100 Actuator

CVS Sizes 35, 50, 60, 70 Scotch Yoke Hydraulic Actuator

Introduction

The CVS Hydraulic Actuator uses a scotch yoke mechanism to convert linear piston motion to a 90 degree rotation. The actuator incorporates key materials for construction, such as aluminum drive case, fiber wound cylinders, and do not use brass or bronze components to allow for use in sour gas applications.

The CVS Scotch Yoke Hydraulic actuator is well suited for operating plug, ball, butterfly, dampers and other devices requiring 90° turn rotation.

(±4° of additional angle adjustment)

Head Office
3900 101 Street
Edmonton, Alberta
T6E 0A5
Canada
Office: (780) 437-3055
Fax: (780) 436-5461

CVS
Controls Ltd.

Website: www.cvs-controls.com

Email: info@cvs-controls.com

Calgary Sales Office
205, 2323 – 32 Avenue NE
Calgary, Alberta
T2E 6Z3
Canada
Office: (403) 250-1416
Fax: (403) 291 9487

Features

- Scotch Yoke Mechanism, high breakaway and reseat torque
- $\pm 4^\circ$ of additional angle adjustment
- Can be used for fail open, or closed
- Light weight Aluminum Drive Case
- Light weight and durable Fiber Wound Cylinders
- Standard operating temperature range: -50°C to $+80^\circ\text{C}$ (-58°F to $+176^\circ\text{F}$)
- Safe reliable spring cartridges to allow removal for field service
- Stainless Steel Stem and Drive Rod components
- Fully Serviceable

Installation

Align actuator and valve in the same position, open or closed. Check mounting surfaces and orientation of the actuator to the valve for any misalignment. Set actuator into position on valve, and install all bolts and nuts. Align actuator and valve stem; tighten mounting bolts evenly to torque specifications (20-30 ft-lb). The CVS scotch yoke actuator is tested and set to fully open or fully closed positions at point of manufacturing. Refer to the **Adjustments** portion of this manual should there be further adjustments required.

Determine Fail Safe Action

With the actuator horizontal, cylinders extended to the sides, and the stem closest to you (vertical), a spring side housing (long cylinder) to the right will indicate a “fail open”, while a spring side housing to the left will indicate a “fail closed”

Maintenance

O-ring, gasket, and bushing replacement are the only expected servicing that may be required under normal operating conditions. Contact your CVS Controls representative for service and repair kits. Specify model and serial number when ordering.

Disassembly

- Ensure no hydraulic pressure is being applied to the actuator. Disconnect all piping and remove the actuator from the valve.
- Remove jam nut (28), flat washer (27), and o-ring (26) from both end caps (22), remove end stop (25)
- Place actuator with cylinders extended to the side

Spring Side Disassembly

- Carefully release preload of spring side cylinder (20b) by evenly loosening stay rod nuts (24)

Disassembly Continued,

- Completely remove stay rod nuts(24) and lock washers (23)
- Remove end cap (22), which allows for removal of spring cartridge

***Note: Do not disassemble spring cartridge (29 thru 34). This is a self contained unit under compression, and may cause injury if disassembled incorrectly.**

- Remove spring side cylinder (20B)
- Remove stay rods (21)

Piston Side Disassembly

- Remove cylinder bolts (37), and lock washers (23) from piston side
- Take end cap (22) off of piston cylinder
- Carefully slide piston cylinder (20) off of piston
- Remove lock nut (18) to allow for removal of piston (15), piston seal (17), and o-ring (16)
- Remove cylinder plate (12), gasket (19), drive rod guide (13), and drive rod seal (14)

Drive Case Disassembly

- Remove drive rod (4) and roller assembly (5 thru 7). Remove snap rings (7), rollers (6) and drive pin (5) from drive rod (4)
- Remove cover screws (10) and cover (2)
- Remove indicator (11) after marking original position. Drive yoke pin (3c) out of stem. (pin must be driven out of yoke

towards markings stamped on the yoke itself as the yoke pin is tapered and can only be removed one way)

- Remove snap rings (3d), stem will now be ready to slide out of case and yoke will be free to take out of case
- Remove o-rings (9) from stem
- Remove bushings (3d) from drive case

Inspection and Cleaning

Inspect o-rings, bushings and gaskets for damage and replace if necessary. Check cylinder bore for scoring. Inspect metal components for wear, corrosion or damage. All parts excluding gaskets (19), may be cleaned with varsol or equivalent as required.

After cleaning, lubricate yoke slots, drive pin, rollers, bushings and guides with a light coat of grease. Apply lubrication to all o-rings.

Assembly

- Install bushings (8) into drive case (1)
- Install o-rings (14) into cylinder plate (12) prior to installing drive rod guide (13)
- Install one o-ring (9) onto stem (3b) and install into case (1) through yoke (3)
- Install another o-ring (9) on stem (3b), and install snap rings (3d) on stem (3b)

Assembly Continued,

- Align stem (3b) with yoke (3) and ensure yoke pin (3c) will line up correctly as the pin is tapered and will only correctly install in one direction, install yoke pin (3c) by gently tapping into yoke (3) and stem (3b) with a hammer
- Make up drive rod assembly by installing drive pin (5), slide drive rollers (6) onto pin (5) and install two snap rings (7)
- Slide completed drive rod assembly through case (1) and position rollers between yoke arms
- Lubricate yoke, drive rod assembly and stem

Spring side cylinder assembly

- Install cylinder plate (12) over drive rod assembly on both sides of case (1), ensure vent holes are in same position on both sides
- Install piston center o-ring (16) on both sides of drive rod assembly
- Install piston (15), (15b) onto drive rod assembly using piston lock nut (18)
- Insert four stay rods (21) into case and tighten
- Place cylinder gasket (19) on cylinder plate (12) and end cap (22)
- Install spring side cylinder (20b)
- Place spring assembly in spring side cylinder (20b)
- Install end cap (22) over stay rods (21), vent hole on end cap (22) should be

opposite the vent hole of cylinder plate (12)

- Using four lock washers (23) and four stay rod nuts (24), evenly tighten end cap (22) over spring side cylinder (20b), ensure proper alignment of cylinder
- Torque stay rod nuts (24) to 27 ft lbs.

Piston side cylinder assembly

- Install piston o-ring (17) onto piston (15)
- Place gasket (19) on cylinder plate (12) and end cap (22)
- Slide piston side cylinder (20) over piston (15)
- Install end cap (22) using four cylinder bolts (37) and four lock washers (23), ensure vent hole on end cap (22) is opposite vent hole of cylinder plate (12)
- Torque cylinder bolts (37) to 27 ft lbs.
- Install cover (2) by first applying a silicone sealant around edge of cover, inside bolt pattern to ensure a weather proof seal, install four cover screws (10)

End Stop Installation and Adjustments

- Install end stop (25) into center hole of end caps (22), slide end stop o-ring (26) over end stop, place end stop washer (27) over end stop and install jam nut (28)
- Tighten or loosen end stop (25) to adjust travel for fully open or closed operation, tighten jam nut when set.

Torques

Actuator Model	Min. Operating Pressure (PSIG)	Max. operating Pressure (PSIG)	Calculated Spring Unloading Torque (in.lb) Starting	Calculated Spring Unloading Torque (in.lb) Mid-Stroke	Calculated Spring Unloading Torque (in.lb) Ending	Calculated Hyd. Loading Torque at Min. Operating Pres. (in.lb) Starting	Calculated Hyd. Loading Torque at Min. Operating Pres. (in.lb) Mid-Stroke	Calculated Hyd. Loading Torque at Min. Operating Pres. (in.lb) Ending
Series 35	200	275	2730	1060	1530	2710	1050	1500
Series 50	800	2000	9770	3870	5700	8440	3200	4370
Series 60	1000	2000	16300	6440	9420	12200	4630	5280
Series 70	800	2000	27700	10900	15800	25800	9910	13800

Table 1: Torques

Testing and Trouble Shooting

- With pressure applied to the actuator check gaskets and end stops with soap and water or other leak detecting fluid. A leak may indicate that fasteners may need to be tightened or gaskets/o-rings may need to be replaced.
- Check for leakage from opposite side of the piston. A leak may indicate the necessity to replace the o-rings.
- If the actuator has not been operated for a long period of time, some leakage past piston seals may be observed upon start up. Cycling the actuator a few times may cause the o-rings to regain their resiliency and stop this leakage. Should leak continue, o-rings/gaskets may need to be replaced.

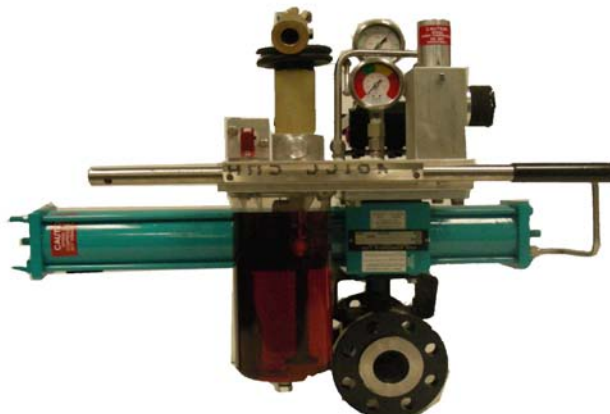

CVS Series 35 SRM 100 with CVS Self Contained Hydraulic Pump, CVS 500 Limit Switch, and CVS Ball Valve.

CVS Series 35 SRM100 Actuator Assembly

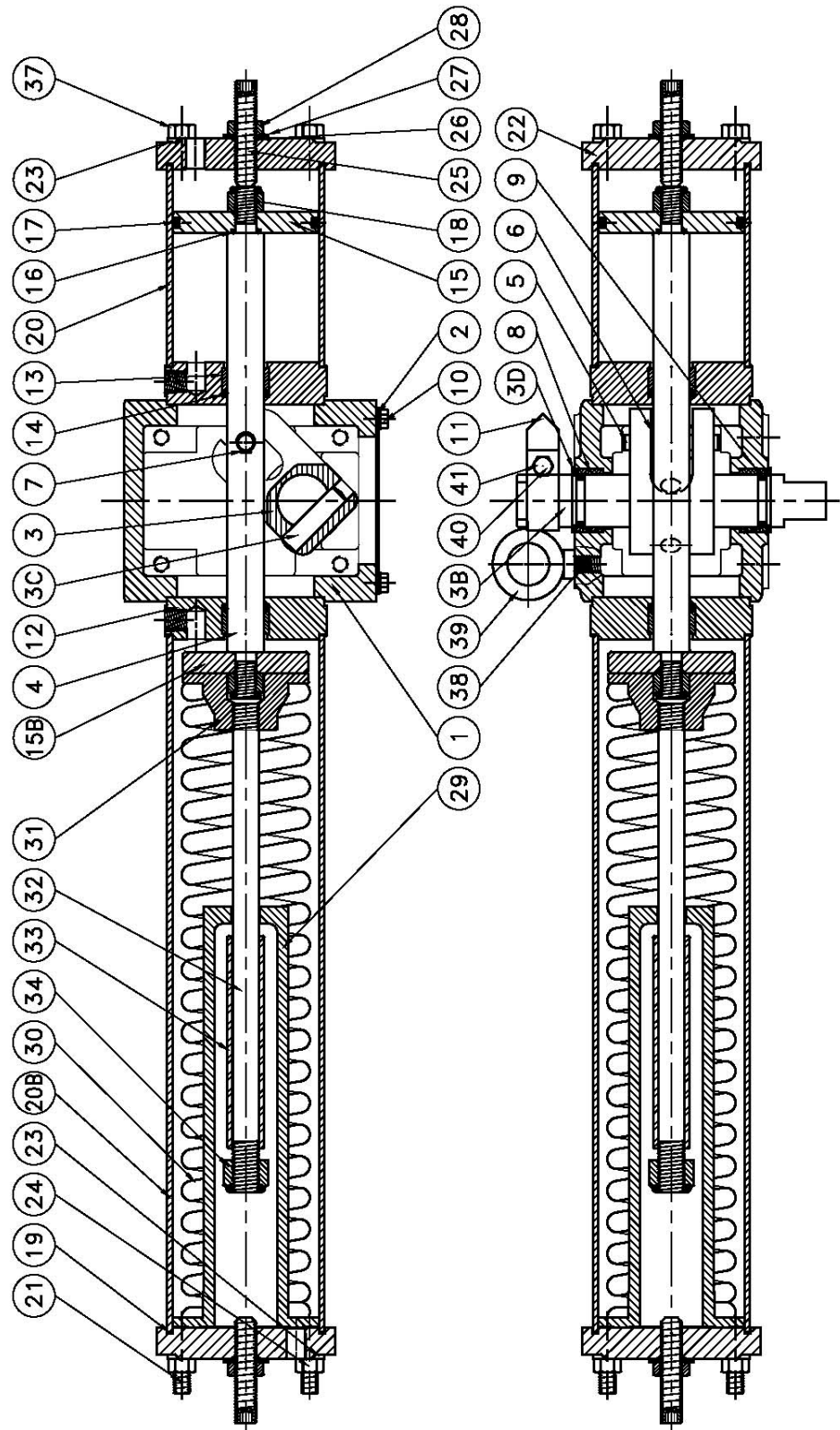

Figure 2: CVS Series 35 SRM100 Assembly

CVS Series 35D SRM100 Parts Listing

Item	Qty	Material Description, Part Number
1	1	Drive Case, CVS 35D0001
2	1	Cover, CVS 35D0002
3	1	Yoke, CVS 35D0003
3B	1	Stem, CVS 35D0003B
3C	1	Yoke Pin, CVS 35D0003C
3D	2	Snap Ring, CVS 35D0003D
4	1	Drive Rod, CVS 35D0004
5	1	Drive Pin, CVS 35D0005
6	2	Drive Roller, CVS 35D0006
7	2	Snap Ring, CVS 35D0007
8	2	Bushing, CVS 35D0008
*9	2	O-Ring, CVS 35D0009
10	4	Cover Screw, CVS 35D0010
11	1	Indicator, CVS 35D0011
12	2	Cylinder Plate, CVS 35D0012
13	2	Drive Rod Guide, CVS 35D0013
*14	2	Drive Rod Seal, CVS 35D0014
15	1	Piston, CVS 35D0015
15B	1	Piston, CVS 35D0015B
*16	2	Piston Center O-ring, CVS 35D0016
*17	1	Piston O-ring, CVS 35D0017
18	2	Piston Lock Nut, CVS 35D0018
*19	4	Cylinder Gasket, CVS 35D0019
20	1	Cylinder, CVS 35D0020
20B	1	Cylinder, CVS 35D0020B
21	4	Stay Rod, CVS 35D0021
22	2	End Cap, CVS 35D0022
23	8	Lock Washer, CVS 35D0023
24	4	Stay Rod Nut, CVS 35D0024
25	2	End Stop, CVS 35D0025
*26	2	End Stop O-ring, CVS 35D0026
27	2	End Stop Washer, CVS 35D0027
28	2	Jam Nut, CVS 35D0028
29	1	Barrel, CVS 35D0029
30	1	Spring, CVS 35D0030
31	1	Retainer, CVS 35D0031
32	1	Rod, CVS 35D0032
33	1	Spacer, CVS 35D0033
34	1	Lock Nut, CVS 35D0034
37	4	Cylinder Bolt, CVS 35D0037
38	3	Set Screw, CVS 35D0038
39	1	Eye Bolt 3/8", CVS 35D00030
40	1	Indicator Screw 1/4, CVS 35D0040
41	1	Indicator Nut 1/4, CVS 35D0041

***Recommended Spare Parts**

Table 2: 35D SRM100 Parts Listing

Torque Specifications – CVS Series 35

Item Description	Item Number	Torque ft-lb Series 35	Torque ft-lb Series 50	Torque ft-lb Series 60	Torque ft-lb Series 70
Cover Screws	10	10	10	10	10
Stay Rod-Nuts/Bolts	21, 24	20-30	50	80	80-100
Piston Nut	18	80	100	100	100
Cylinder Bolts	37	20-30	50	50	50
Mounting Bolts- 3/8NC X 1-1/4 inch	Not Supplied	20-30	50	80	100

Table 3: Torque Specifications

Drive Case and Mounting Dimensions, Top View (inches)

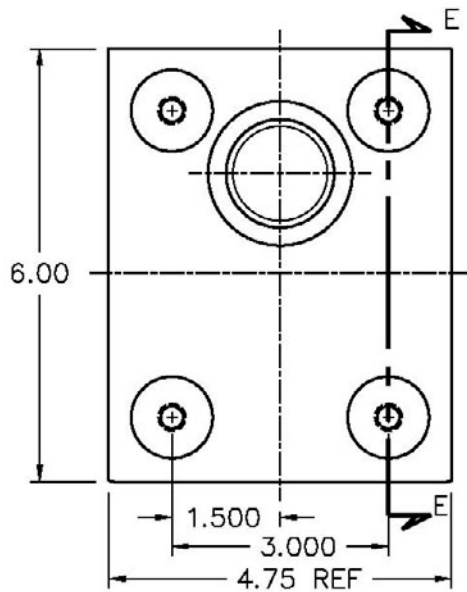

Figure 3: Drive Case

CVS Series 35 SRM100 Dimensions (inches)

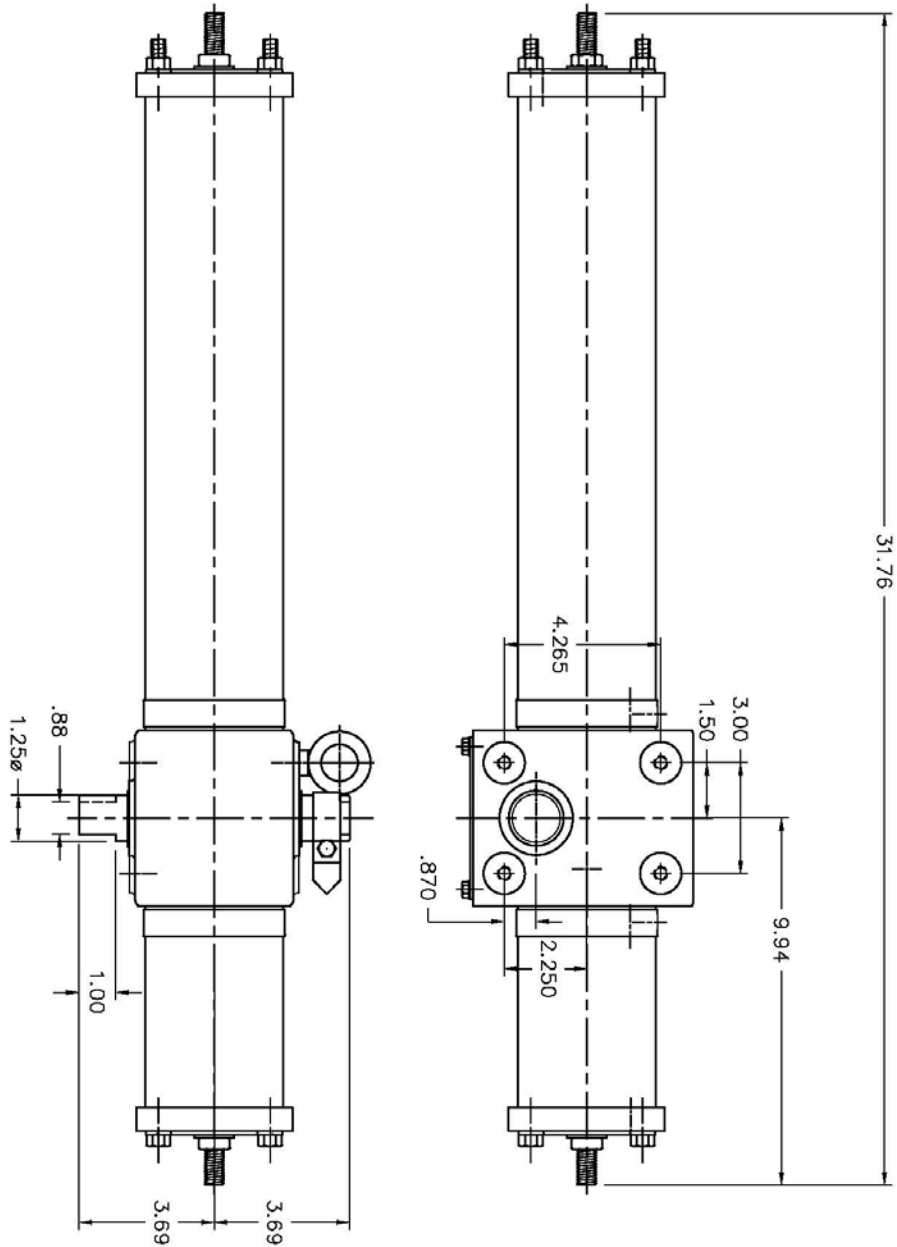

Figure 4: CVS Series 35 SRM100

CVS Controls Ltd. strives for the highest levels of quality and accuracy. The information included in this publication is presented for informational purposes only. CVS Controls Ltd. reserves the right to modify or change, and improve design, process, and specifications without written notice. Under no circumstance is the information contained to be interpreted to be a guarantee/warranty with regard to our products or services, applicability or use.

Selection, use and maintenance are the sole responsibility of the end user and purchaser. CVS Controls assumes no liability for the selection use and maintenance of any product.

Notes:

Notes:

CVS

Controls Ltd.

Head Office

3900 101 Street
Edmonton, Alberta
T6E 0A5
Canada
Office: (780) 437-3055
Fax: (780) 436 5461

Calgary Sales Office

205, 2323 – 32 Avenue NE
Calgary, Alberta
T2E 6Z3
Canada
Office: (403) 250-1416
Fax: (403) 291-9487

Website: www.cvs-controls.com

Email: info@cvs-controls.com

Global Supply Line Australia - Supplying worldwide, major stockists www.globalsupplyline.com.au