

Bettis RPE-Series Pneumatic Actuator

Dependable Performance For The Toughest Environments



BETTIS™



Approved Emerson-Bettis distributor, service facility and stockist.
www.globalsupplyline.com.au sales@globalsupplyline.com.au
Full stock list [click here](#)



Bettis RPE-Series

The RPE-Series is the heavy duty rack & pinion actuator from Bettis. Its rugged industrial design offers a tough “workhorse” range of valve actuators due to a unique set of features.

These features combine to provide a reliable actuator that:

- Improves valve automation to ensure your plant uptime and prevent unplanned downtime
- Makes your installation and maintenance simple and easy due to the standardized customer interfaces
- Allows you to apply the actuator indoors and outdoors, at extreme temperatures, harsh duty and corrosive atmospheres



The Right Size of Actuator

Spring-return actuator can be equipped with up to 6 individual pocket springs on each side of the actuator. This allows you to select and configure the most economical actuator size for your application.

The robust and “work-horse” performance actuator for any harsh environment

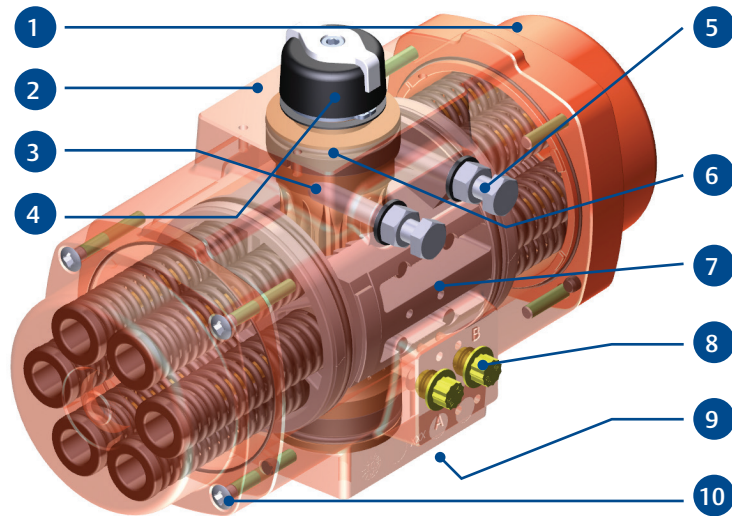

1. Heavy duty body castings provide maximum protection in the harsh environment of process plant locations
2. Polyurethane powder coating provides excellent corrosion resistance on housing and end caps
3. One piece blow-out proof, pressure balanced, pinion allows safe in-field re-configuration from Fail-Close to Fail-Open. The use of aerospace type alloy 7075 T6, provides the best combination of corrosion resistance, high strength and a lightweight construction as well as providing protection against galvanic corrosion
4. VDI/VDE 3845 (NAMUR) top accessory interface
5. Precision dual stroke adjustment provides accurate and intuitive end of stroke adjustment for the Open and Closed valve position
6. Low maintenance bearings for pistons and pinion
7. Accurately designed and machined components assure a perfect fit and long cycle life
8. VDI/VDE 3845 (NAMUR) solenoid interface
9. Dual ISO 5211 mounting patterns allow low-profile direct mounting to valves
10. Stainless steel or Deltatone® coated fasteners

General Specifications

Torque Range:	Double-Acting 119 to 39498 lbf.in (13.4 to 4449 Nm)	
	Spring-Return 20 to 21188 lbf.in (2 to 2394 Nm; spring end torque)	
Rotation:	Factory set at 90°	
Temperature Range:	-4°F to 175°F (-20°C to 80°C)	
Finish:	Body and end caps: Cast aluminium, anodized and polyurethane powder coated	Pinion: High grade aluminium, hard anodized
	Pistons: Chromated	Fasteners: Stainless steel or Deltatone® coated
Lubrication:	Lubricated for life	
Pressure Range:	2.9 to 120 psig (0.2 to 8.3 barg)	
Pressure Media:	Air, dry or lubricated and inert gases	

Advanced Design leads to Application Flexibility

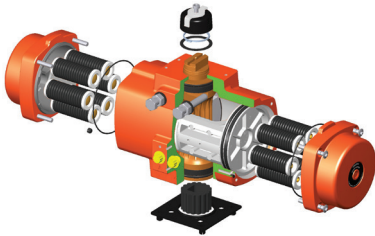

Advanced design techniques

Bettis RPE-Series is the result of 40-years of production and design refinement following stringent engineering standards to perform under the toughest, heavy duty applications

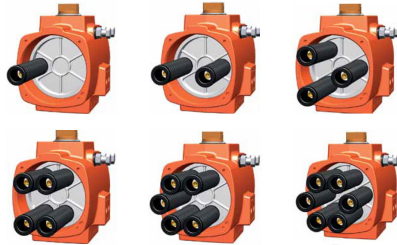

Modular Construction allows the maximum flexibility across a wide range of applications. In addition, new spring design allow for different air pressures to fit choice of valve

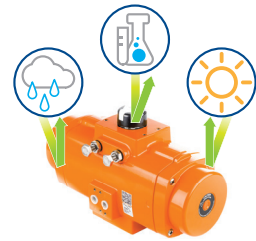

Maximum corrosion protection in every Bettis RPE is achieved by using anodized body and end cap, stainless steel or Deltatone® coated external steel parts and a polyurethane powder coat. It is tested to exceed 1000 hours salt spray to the ASTM B117 standard to assure a corrosion free long service life

Ease of Use from Installation to Configuration to Maintenance

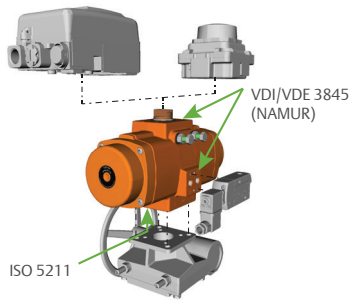

Compliance to the relevant interface standards ensures standardization of the valve mounting, solenoid mounting and top mounted switch box or positioner mounting

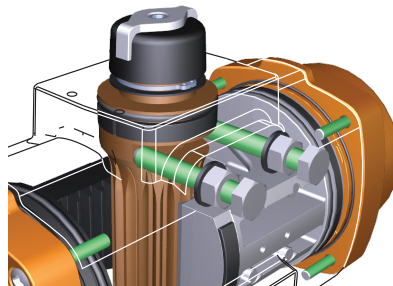

Dual Stroke Adjustment provides precise intuitive end of stroke adjustment for the Open and Closed valve position

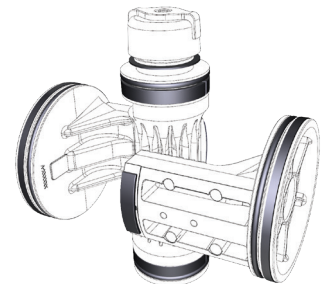

Low Maintenance Bearings

The actuator is lubricated for life. Together with the high performance synthetic bearings, the actuator provides long working life with low maintenance requirements

Safety, Performance and Global Compliance

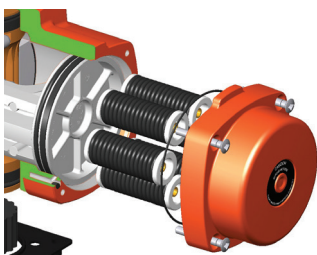

Functional and personal safety is your plant's number one priority. The spring cartridge design provides maximum personnel safety during maintenance and ensures that "Fail Safe" actuators will always do just that

Quality	ISO9001:2008	✓
Valve Flange	ISO 5211	✓
Solenoid	VDI/VDE3845	✓
Top Accessories	VDI/VDE3845	✓
Explosive Areas	ATEX	✓
Pressure Safety	PED	✓
Mechanical Safety	MD	✓

Bettis RPE pneumatic actuators are manufactured to meet **worldwide quality and safety standards**

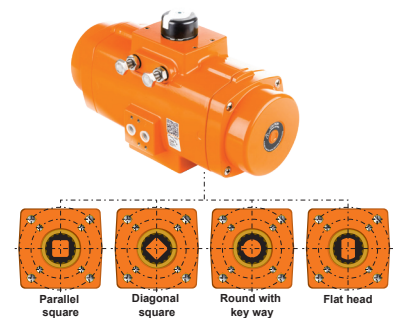

Drive inserts and dual drilling patterns on the valve flange **make direct mounting flexible**, no matter if the valve stem is; square, flat head, or round with key way



Certifications

Betts RPE-Series pneumatic actuators are manufactured to meet the following worldwide quality and safety standards:

Safety Standards



Product Interface Standards

VDI/VDE3845 (NAMUR)
ISO – 5211

Company Operations Standards

ISO – 9001 Quality Assurance

This product is only intended for use in large-scale fixed installations excluded from the scope of Directive 2011/65/EU on the restriction of the use of certain hazardous substances in electrical and electronic equipment (RoHS 2).



For complete technical and installation documentation, scan QR.

<http://www.emerson.com/bettis>

Reliable single source supplier

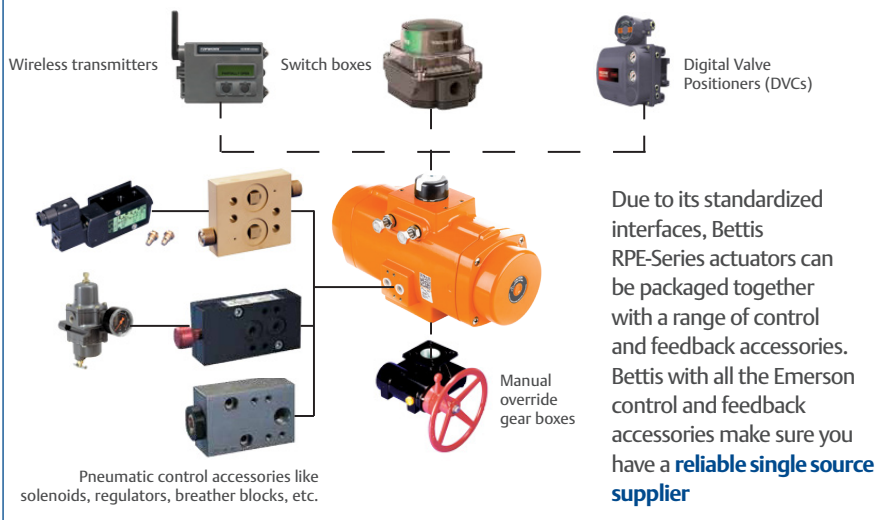

World Area Configuration Centers (WACC) offer sales support, service, inventory and commissioning to our global customers. Choose the WACC or sales office nearest you:

NORTH & SOUTH AMERICA

19200 Northwest Freeway
Houston TX 77065
USA
T +1 281 477 4100

Av. Hollingsworth
325 Iporanga Sorocaba
SP 18087-105
Brazil
T +55 15 3413 8888

ASIA PACIFIC

No. 9 Gul Road
#01-02 Singapore 629361
T +65 6777 8211

No. 1 Lai Yuan Road
Wuqing Development Area
Tianjin 301700
P. R. China
T +86 22 8212 3300

MIDDLE EAST & AFRICA

P. O. Box 17033
Jebel Ali Free Zone
Dubai
T +971 4 811 8100

P. O. Box 10305
Jubail 31961
Saudi Arabia
T +966 3 340 8650

24 Angus Crescent
Longmeadow Business Estate East
P.O. Box 6908 Greenstone
1616 Modderfontein Extension 5
South Africa
T +27 11 451 3700

EUROPE

Holland Fisor 6
Székesfehérvár 8000
Hungary
T +36 22 53 09 50

Strada Biffi 165
29017 Fiorenzuola d'Arda (PC)
Italy
T +39 0523 944 411

For complete list of sales and manufacturing sites, please visit www.emerson.com/actuationtechnologieslocations or contact us at info.actuationtechnologies@emerson.com

©2018 Emerson. All rights reserved.

The Emerson logo is a trademark and service mark of Emerson Electric Co. Betts™ is a mark of the Emerson family of companies. All other marks are property of their respective owners.

BETTIS™

DOC.4P.BRPE.UK Rev C 06-18

Bettis RPE-Series

Rack and Pinion Pneumatic Actuators

- High quality and economical actuator
- Improve plant and operator safety
- Reliable and flexible in process control
- Increase serviceability



Table of Contents

Section 1: General

General Specifications	4
Construction, Parts and Materials	6
Bettis RPE-Series Corrosion Protection System	9
Assembly Codes Bettis RPE-Series actuators	10

Section 2: Product Configuration Code

Product configuration code	11
----------------------------------	----

Section 3: Torque

Actuator Torque - Spring-Return (Nm)	13
Actuator Torque - Spring-Return (lbf.in)	15
Actuator Torque - Double-Acting (Nm)	17
Actuator Torque - Double-Acting (lbf.in)	18
Sizing of Rack & Pinion actuators	19
Spring Cartridge placement	21

Section 4: Dimensions

Dimensions - Metric (ISO5211).....	24
Dimensions - Metric (DIN3337).....	27
Dimensions - Imperial (ISO5211).....	30

Section 5: Integral Options

Drive Inserts	33
Center Plate / Center ring	37
Visual indicator Bettis RPE-Series actuators	38
High Temperature Execution	39
Low Temperature Execution	40
Bettis RPE-Series with Stainless Steel pinion.....	41
Fast Cycling RPE-Series actuators.....	43
Actuator for use with natural gas	45

Table 1. Actuator Weight

Actuator Model	Double Acting		Spring Return Springset N=6	
	lbs	Kg	lbs	Kg
RPE 25	3.1	1.4	3.5	1.6
RPE 40	4.6	2.1	5.1	2.3
RPE 65	6.2	2.8	7.3	3.3
RPE 100	7.7	3.5	9.5	4.3
RPE 150	10.8	4.9	14.6	6.6
RPE 200	13.2	6.0	18.3	8.3
RPE 350	22	10.2	32	14.5
RPE 600	44	20	57	26
RPE 950	58	26	89	41
RPE 1600	91	41	137	62
RPE 2500	141	64	221	100
RPE 4000	226	103	325	147

Table 2. Cycle time in seconds

Actuator Model	Spring Return		Double acting	
	Opening Stroke	Closing Stroke	Opening Stroke	Closing Stroke
RPE 25	0.5	0.4	0.5	0.4
RPE 40	0.6	0.5	0.6	0.5
RPE 65	0.7	0.5	0.6	0.6
RPE 100	0.8	0.6	0.8	0.7
RPE 150	1.0	0.8	0.9	0.8
RPE 200	1.3	0.9	1.0	1.0
RPE 350	1.9	1.3	1.4	1.5
RPE 600	3.2	1.9	2.2	2.2
RPE 950	6.6	2.2	2.4	2.0
RPE 1600	10.6	3.5	3.6	3.3
RPE 2500	16.9	5.7	5.8	5.2
RPE 4000	29.1	9.2	9.2	9.0

1. Test conditions:
2. Solenoid with flow capacity: 0.6 m3/hr
3. Pipe diameter: 6 mm
4. Medium: clean air
5. Supply pressure: 5.5 bar/80psi
6. Load: with average load
7. Stroke: 90°
8. Temperature: Room temperature

General Specifications

Torque Range

- Double-Acting: 220 to 38510 lbf.in (25 to 4338 Nm) at 80psig (5.5 barg)
- Spring-Return: 118 to 15867 lbf.in (5 to 1793 Nm) spring end torque at maximum spring set.

Pressure Range

- Double-Acting:
 - 2.9 to 120 psig (0.2 to 8.3 barg)
- Spring-Return:
 - 87 to 120 psig (6 to 8.3 barg), with maximum spring set
 - 43.5 to 120 psig (3 to 8.3 barg), reduced spring quantity

Pressure Media

- Air, dry or lubricated and inert gases
- Dew point at least 10K below ambient temperature
- For sub-zero applications, take appropriate measures
- Mentioned pressure levels are "gauge pressures". Gauge pressure is equal to absolute pressure minus atmospheric pressure.

Cycle life

- Normal working life is 500,000 cycles according EN15714-3, where 1 cycle is 1 open stroke and 1 close stroke.

Finish

- Body: Anodized and polyurethane powder coated
- End caps: Anodize and polyurethane powder coated
- Pistons: Chromated
- Pinion: Hard Anodized
- Fasteners: Stainless steel or Deltatone® coated

Lubrication

- Castrol High Temperature grease (or equivalent)

Temperature Range

- Standard: -4°F to +176°F (-20°C to +80°C)
- Option:
 - Low temperature: -40°F to +176°F (-40°C to +80°C)
 - High temperature: +14°F to +250°F (-10°C to +120°C)

Angle of Rotation

- Factory set at 90°
- Adjustable range:
 - Size 25 to 600: -5° to +10° and +80° to 95°
 - Size 950 to 4000: -3° to +10° and +80° to 93°

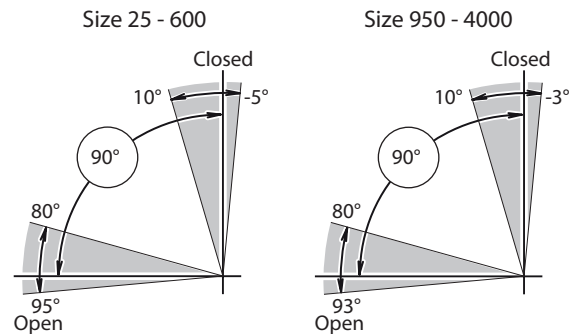

Compliance to International Standards

- Valve flange: ISO 5211/DIN3337
- Solenoid flange: VDE/VDI 3845 (NAMUR)
- Accessory flange: VDE/VDI 3845 (NAMUR)
- European Directives: ATEX, PED and Machinery Directive.
- For RoHS2 compliance contact your nearest Emerson representative.
- SIL 3 rated according to IEC 61508-1-7:2010
- EAC Customs union: Compliance to Russian TR010 and TR012

Table 3. Actuator air volumes and consumption

Actuator model	Actuator volumes:			Consumption per stroke (in liters, pressure in barg)					
	Maximum volume (in liters)			Outward Stroke			Inward Stroke		
	Central1 chamber	End cap2 chamber	Displace3 volume	Double acting and Spring Return			Double acting only		
				2.0 barg	4.0 barg	8.0 barg	2.0 barg	4.0 barg	8.0 barg
RPE 25	0.14	0.20	0.08	0.36	0.64	1.2	0.48	0.88	1.7
RPE 40	0.26	0.37	0.15	0.67	1.2	2.2	0.89	1.6	3.1
RPE 65	0.40	0.56	0.22	1.02	1.8	3.4	1.3	2.4	4.7
RPE 100	0.6	0.9	0.3	1.5	2.7	5.0	2.0	3.8	7.2
RPE 150	1.0	0.8	0.5	2.4	4.3	8.1	2.1	3.6	6.7
RPE 200	1.3	1.0	0.7	3.2	5.7	11	2.8	4.9	9.1
RPE 350	2.1	1.9	1.2	5.5	9.8	18	5.0	8.8	16
RPE 600	3.6	3.3	2.1	9.4	17	31	8.7	15	28
RPE 950	4.9	4.6	3.2	13	23	43	12	22	40
RPE 1600	7.9	7.3	5.4	21	37	69	20	35	64
RPE 2500	12.6	11.9	8.3	34	59	109	32	56	104
RPE 4000	21.7	19.0	13.5	57	100	187	52	89	165

Notes:

1. 1. For Double-acting and Spring-return. Pistons at 90° outward position
2. 2. Only for Double-acting. Pistons at 0° inward position
3. 3. Stroke is 90°

**Central air chamber volume
Double-Acting and Spring-Return**

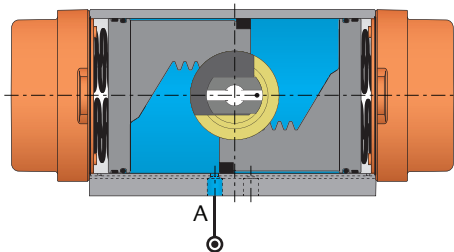

**End cap air chamber volume
Double-Acting only**

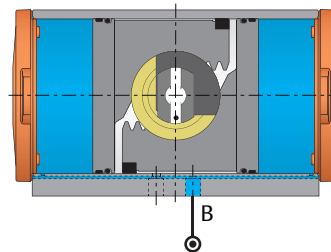

Construction, Parts and Materials RPE25-RPE600

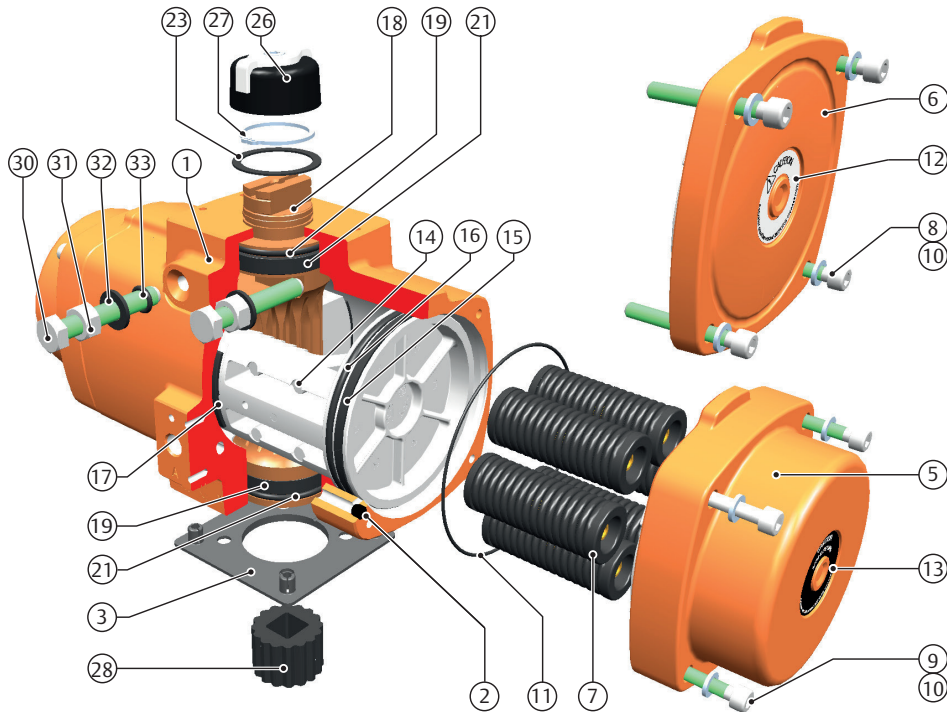

Notes:

- 1 Included in Service Kit.
- 2 Anodized and polyurethane powder coated.
- 3 Chromated
- 4 Hard anodized
- 5 Electrophoretic coated
- 6 Deltatone® coated
- 7 Anodized
- 8 High end caps for double-acting and spring-return models up to size RPE100. Low end caps for double-acting models for sizes RPE150 and larger.

Pos.	Qty	Notes	Description	Material
1	1	2	House	Cast Aluminium alloy
2	2	1	B-port seal	Nitrile rubber
3	1		Center plate (option)	Nylon PA6, Black
5	2	2, 8	End cap SR (DA)	Cast Aluminium alloy
6	2	2, 8	End cap DA	Cast Aluminium alloy
7	Max. 12	5	Spring cartridge	Spring steel
8	8		End cap screw DA	Stainless Steel
9	8		End cap screw SR	Stainless Steel
10	8		End cap screw washer	Stainless Steel
11	2	1	O-ring end cap	Nitrile rubber
12	2		Warning sticker DA	Polyester
13	2		Warning sticker SR	Polyester
14	2	3	Piston	Cast Aluminium alloy
15	2	1	Bearing piston	PTFE 25% carbon-filled
16	2	1	O-ring piston	Nitrile rubber
17	2	1	Bearing strip piston rack	POM
18	2	4	Pinion	High grade aluminium
19	2	1	Bearing pinion	POM
21	2	1	O-ring pinion	Nitrile rubber
23	1	1	Thrust bearing pinion	POM, black UV stabilized
26	1		Indicator assembly	ABS + stainless steel screw
27	1	1, 6	Circlip	Spring steel
28	1	7	Drive insert	Aluminium
30	2		Limit stop screw	Stainless steel
31	2		Limit stop nut	Stainless steel
32	2	1	Limit stop washer	PA66
33	2	1	O-ring limit stop	Nitrile rubber

Construction, Parts and Materials RPE950-RPE2500

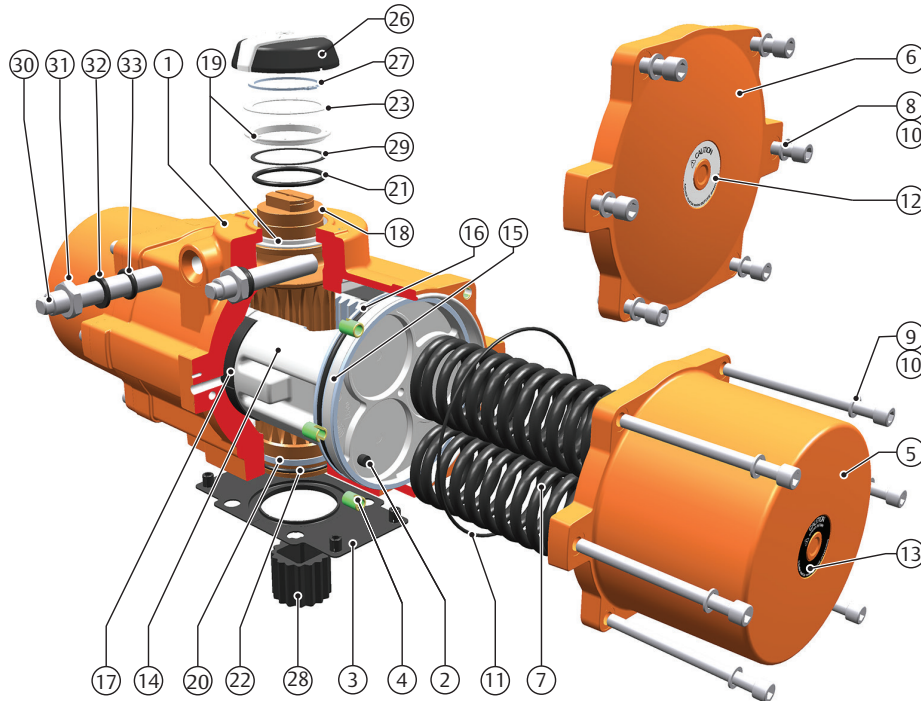

Notes:

- | | | | |
|---|-----------------------------------------|---|------------------------|
| 1 | Included in Service Kit. | 5 | Electrophoretic coated |
| 2 | Anodized and polyurethane powder coated | 6 | Deltatone® coated |
| 3 | Chromated | 7 | Anodized |
| 4 | Hard anodized | 8 | 8x for Size 950 |

Pos.	Qty.	Notes	Description	Material
1	1	2	House	Cast Aluminium alloy
2	2	1	B-port seal	Nitrile rubber
3	1		Center plate (option)	Nylon PA6, Black
4	8/12	8	Thread insert	Steel
5	2	2	End cap SR	Cast Aluminium alloy
6	2	2	End cap DA	Cast Aluminium alloy
7	Max. 6	5	Springs	Spring steel
8	8/12	8	End cap screw DA	Stainless Steel
9	8/12	8	End cap screw SR	Stainless Steel
10	8/12	8	End cap screw washer	Stainless Steel
11	2	1	O-ring end cap	Nitrile rubber
12	2		Warning sticker DA	Polyester
13	2		Warning sticker SR	Polyester
14	2	3	Piston	Cast Aluminium alloy
15	2	1	Bearing piston	PTFE 25% carbon-filled
16	2	1	O-ring piston	Nitrile rubber
17	2	1	Bearing strip piston rack	POM
18	1	4	Pinion	High grade aluminium
19	2	1	Bearing pinion top	POM
20	1	1	Bearing pinion bottom	POM
21	1	1	O-ring pinion top	Nitrile rubber
22	1	1	O-ring pinion bottom	Nitrile rubber
23	1	1	Thrust bearing pinion	POM, black UV stabilized
26	1		Indicator assembly	ABS + stainless steel screw
27	1	1, 6	Circlip	Spring steel
28	1	7	Drive insert	Aluminium
29	1	1	Backup ring	POM
30	2		Limit stop screw	Stainless steel
31	2		Limit stop nut	Stainless steel
32	2	1	Limit stop washer	PA66
33	2	1	O-ring limit stop	Nitrile rubber

Construction, Parts and Materials RPE4000

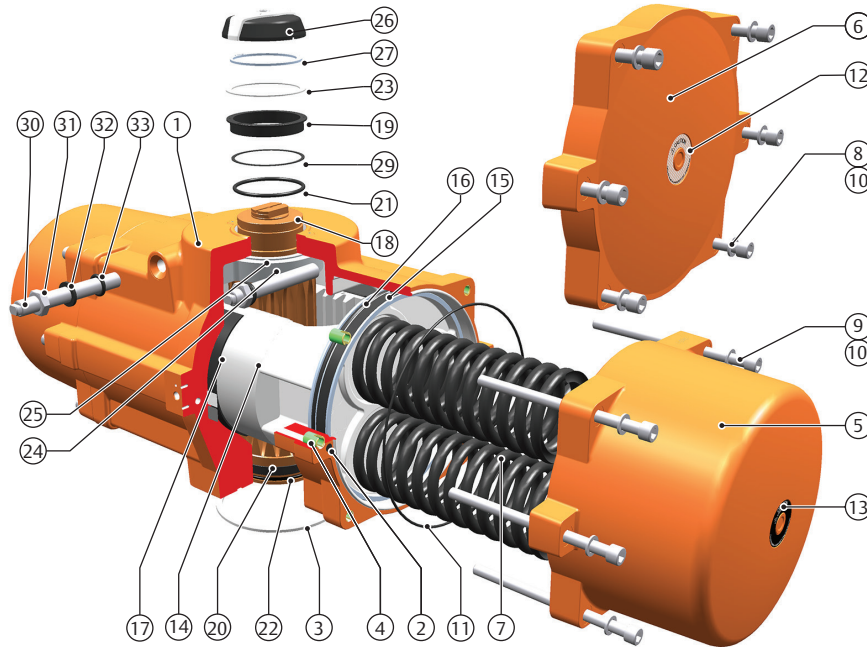

Notes:

- 1 Included in Service Kit.
- 2 Anodized and polyurethane powder coated.
- 3 Chromated
- 4 Hard anodized
- 5 Electrophoretic coated
- 6 Deltatone® coated

Pos.	Qty.	Notes	Description	Material
1	1	2	House	Cast Aluminium alloy
2	2	1	B-port seal	Nitrile rubber
3	1		Center ring	Stainless Steel AISI 304
4	12		Thread insert	Steel
5	2	2	End cap SR	Cast Aluminium alloy
6	2	2	End cap DA	Cast Aluminium alloy
7	Max. 6	5	Springs	Spring steel
8	12		End cap screw DA	Stainless Steel
9	12		End cap screw SR	Stainless Steel
10	12		End cap screw washer	Stainless Steel
11	2	1	O-ring end cap	Nitrile rubber
12	2		Warning sticker DA	Polyester
13	2		Warning sticker SR	Polyester
14	2	3	Piston assembly	Cast Aluminium alloy
15	2	1	Bearing piston	PTFE 25% carbon-filled
16	2	1	O-ring piston	Nitrile rubber
17	2	1	Bearing strip piston rack	POM
18	1	4	Pinion	High grade aluminium
19	1	1	Bearing pinion top	POM
20	1	1	Bearing pinion bottom	POM
21	1	1	O-ring pinion top	Nitrile rubber
22	1	1	O-ring pinion bottom	Nitrile rubber
23	1	1	Thrust washer pinion	POM, black UV stabilized
24	1		Cam stroke adjustment	Steel
25	1	1	Cam thrust washer	POM, black UV stabilized
26	1		Indicator assembly	ABS + stainless steel screw
27	1	1, 6	Circlip	Spring steel
29	1	1	Backup ring	POM
30	2		Limit stop screw	Stainless steel
31	2		Limit stop nut	Stainless steel
32	2	1	Limit stop washer	PA66
33	2	1	O-ring limit stop	Nitrile rubber

Bettis RPE-Series Corrosion Protection System

Description

The corrosion protection system of standard Bettis RPE-Series pneumatic actuators consist of the following treatments or materials:

Electrophoretic finish on springs

Springs are protected from corrosion using an electrophoretic finish.

Anodize pre-treatment

The housing and end caps get an anodize pre-treatment prior to painting. The pre-treatment takes care of a perfect bonding of the paint layer to the aluminium housing and gives additional corrosion protection to the bore of the housing.

Powder coat

- Polyurethane powder coating for exterior use.
- The powder coating is applied cold using automatic electrostatic spray equipment and is cured for about 10 minutes at minimum 200°C (392°F) offering excellent light and weather resistance.
- The powder coating thickness is between 80 and 160 microns (3.15 and 6.3 mils).
- Good chemical resistance against most bases, acids, solvents, alkalis and oils at normal temperatures.
- Excellent exterior mechanical durability.
- The coating has passed a salt spray test according to ASTM B117 for 1,500 hours.

The powder coating is virtually solvent free, and therefore environmentally friendly.

High grade & hard anodized aluminium pinion

Actuators with high grade & hard anodized aluminium pinions, passed a 1,500 hours salt spray test. Optional stainless steel pinions are available for a higher corrosion resistance.

Stainless steel or Deltatone treated external steel parts

External parts are stainless steel or steel alloy with a Deltatone® treatment for optimum protection and durability.

The chemical and durability assessment.

All these components, treatments and finishes, including the durable pinion design, anodized surface finish, standard powder coat paint and Stainless steel treated external fasteners shows no decline of actuator functions up to 1,500 hours salt spray test.

Technical Data

Coating :	Polyurethane powder coating for exterior use.
Salt spray test :	ASTM B117: 1,500 hours
Color :	Orange (RAL 2009)
Materials: Housing:	Anodized aluminium alloy
Endcaps:	Anodized aluminium alloy
Pistons:	Chromated aluminium alloy
Pinion:	High grade aluminium alloy, hard anodized (Option: Stainless steel)
Springs:	Electrophoretic finish
Fasteners:	Stainless steel or alloy steel with Deltatone® treatment
Type Sticker:	Polyester
Application:	Standard Bettis RPE-Series pneumatic actuators

Table 1. Test result polyurethane powder coating

No	Item	Standard	Specification
1	Hardness	ASTM D3363 Pencil (Mitsubishi Uni)	H
2	Adhesion	ISO 2409, ASTM D3359 Cross hatch test (2mm)	Gt (0) 100% Adhesion
3	Impact test	ASTM D2794 5/8" Ball (direct)	Min. 60 lb.in without detachment
4	Bend test	DIN 53152, ISO1519, ASTM D522	Min 3.2 mm without cracking
5	Resistance to humid atmospheres	ASTM D543 3%, H2s04, 4 hours	No Blistering
6	Alkali resistance	ASTM D543 10%, NaOH, 4 hours	No Blistering
7	Water resistance	DIN 500017, min.	No Blistering
8	UV resistance	ASTM G 154 (UVB-313)	Excellent color and gloss retention

1. This data sheet contains general information as supplied by the paint supplier and describes typical properties for the coating.

Assembly Codes Bettis RPE-Series actuators

Spring-return actuators

Assembly code: CW

= Standard, Clockwise-to-Close rotation
= Fail-to-Close

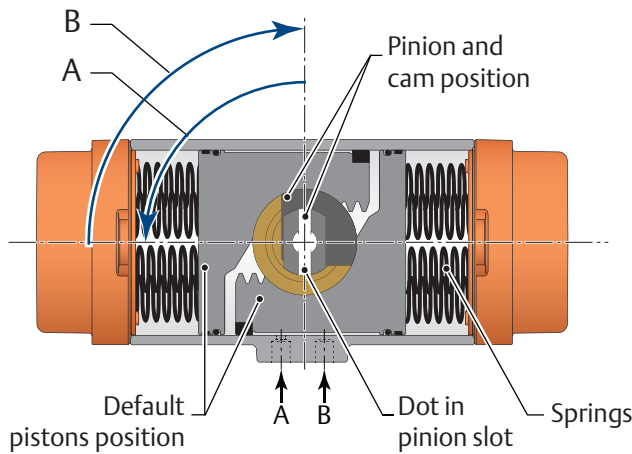

Assembly code: CC

= Reverse, Counterclockwise-to-Open
= Fail-to-Open

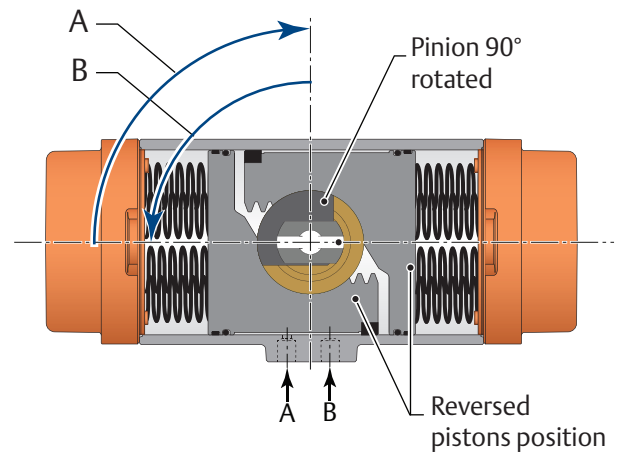

A = Central air chamber pressurized
B = Spring stroke

Double-acting actuators

Assembly code: CW

= Standard, Clockwise-to-Close rotation

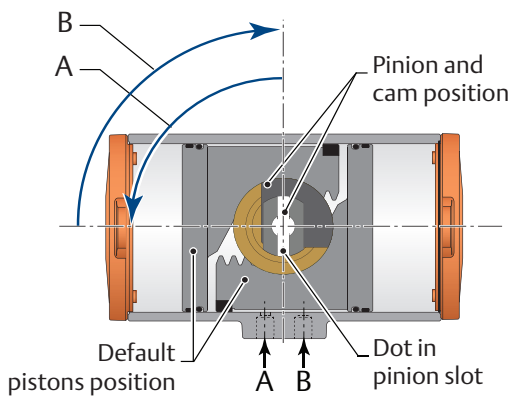

Assembly code: CC

= Reverse, Counterclockwise-to-Open

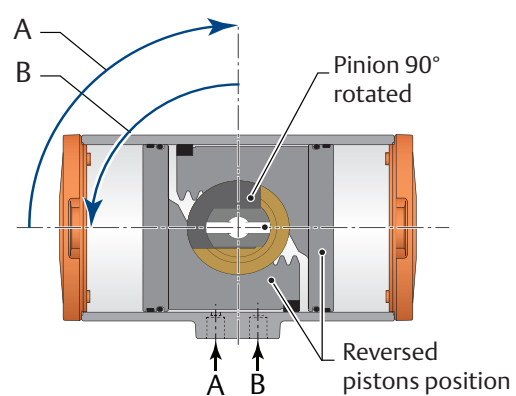

A = Central air chamber pressurized
B = End cap air chambers pressurized

All views are from above. Pistons are shown in inward position.

Product configuration code

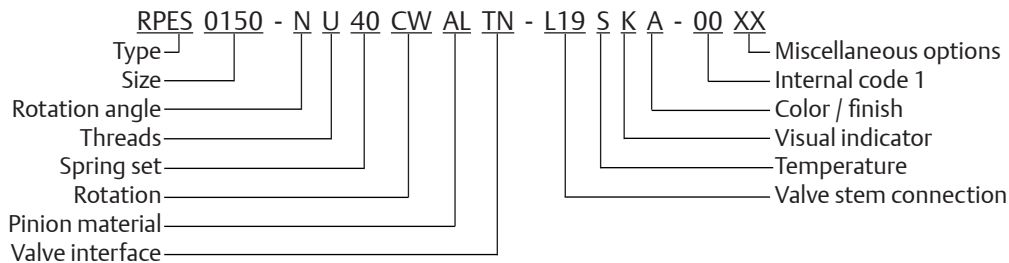

Type			
RPED	Double Acting		
RPES	Spring Return		
Size			
0025	Size 0025	0350	Size 0350
0040	Size 0040	0600	Size 0600
0065	Size 0065	0950	Size 0950
0100	Size 0100	1600	Size 1600
0150	Size 0150	2500	Size 2500
0200	Size 0200	4000	Size 4000
Rotation angle			
N	90° rotation angle		
Threads			
M	Metric ISO 5211		
U	UNC/NPT/Imperial		
Spring Set			
00	Double Acting (no springs)		
10	Spring Set 10	40	Spring Set 40
20	Spring Set 20	50	Spring Set 50
30	Spring Set 30	60	Spring Set 60
Rotation direction			
CW	Spring to Close/Clock Wise		
CC	Spring to Open/Counter Clock Wise		
Pinion Material			
AL	High Grade Aluminium, Hard anodized ⁽⁷⁾		
SS	Stainless steel ASI 316 (+ A4-70 SS fasteners)		
Valve Interface ⁽²⁾			
TN	Standard ISO 5211 interface		
SY	Small interface with center plate (DIN3337)		
LY	Large interface with center plate (DIN3337)		

Notes:
See next page.

Valve Stem Connection				
Actuator size	Square	Aluminum		Stainless Steel ⁽⁴⁾
		Parallel drive ■	Diagonal drive ◆	Star drive ⚙
No insert		000		Not applicable
0025	11mm / 0.433"	L11	D11	Q11
0040 & 0065	14mm / 0.551"	L14	D14	Q14
0100	17mm / 0.669"		D17	Q19
0150	17mm / 0.669"	L19		
	19mm / 0.748"		D17	Q22
0200	22mm / 0.866"	L22	D22	Q22
0350	22mm / 0.866"		D22	Q27
	27mm / 1.063"	L27		
600	27mm / 1.063"	L27	D27	Q27
950	36mm / 1.417"	L36	D36	Q36
1600 & 2500	46mm / 1.811"	L46	D46	Q46
4000 ⁽³⁾	55mm / 2.165"	Q55	Q55	Q55
Temperature Range				
S	Standard: -20°C to +80°C (-4°F to +176°F)			
H	High: -10°C to +120°C (+14°F to +250°F)			
L	Low: -40°C to +80°C (-40°F to +176°F)			
Visual Indication Code				
K	Standard (Knob)			
N	No Visual Indication			
Finish				
B	Standard coating (Bettis Orange)			
Internal code 1				
00	Standard			
10	Stainless steel AISI316 (A4-70) end cap screws ⁽⁷⁾			
Miscellaneous options				
XX	Standard			
H1	1/2" High Flow plate			
P1	1/2" Porting according EN 15714-3 (only sizes 25-600)			

Notes:

1. The options, listed here, are all options available. Not all options apply to all configurations.
2. Valve Interface:
 - Option "S"; Small Interface with Center Plate (DIN3337) is not available for sizes 0025, 0950 and 4000.
 - Option "L"; Large Interface with Center Plate (DIN33337) is not available for sizes 1600 and 2500
 - Option "L" for size 4000 is a stainless steel ring, mounted in a groove in the valve flange.
3. Size 4000 does not have inserts but has two inner squares (diagonally and parallel oriented) directly in the bottom of the pinion.
4. Actuators with stainless steel pinions do not have inserts but have two inner squares (diagonally and parallel oriented aka "Star Drive") directly in the bottom of the pinion.
5. Contact your local Bettis representative for additional insert options.
6. PED Group 1 Label only available up to size 950.
7. Actuators with the default hard anodized pinions, come with stainless steel grade A2 (AISI304) end cap screws.
 - Optional, the actuator is available with stainless steel grade A4-70 (AISI316) end cap screws.
 - Select option 10 in the "Internal code 1" segment in case stainless steel grade A4 (AISI316) end cap screws are required.

Actuator Torque - Spring-Return (Nm)

Actuator Size	Spring set nr.	Spring Stroke Torque (Nm)		Air Torque (Nm)																	
				SUPPLY PRESSURE																	
				3.0 barg		3.5 barg		4.0 barg		4.5 barg		5.0 barg		5.5 barg		6.0 barg		7.0 barg		8.0 barg	
Start	End	Start	End	Start	End	Start	End	Start	End	Start	End	Start	End	Start	End	Start	End	Start	End		
RPES 25	10	4	2	12	10	14	13	17	15	19	17	21	20	24	22	26	25	31	29	36	34
	20	7	4	9	6	12	9	14	11	16	13	19	16	21	18	24	21	28	25	33	30
	30	11	7	7	2	9	4	11	7	14	9	16	12	19	14	21	17	26	21	31	26
	40	14	9	-	-	-	-	9	3	11	5	14	8	16	10	18	12	23	17	28	22
	50	18	11	-	-	-	-	-	-	9	1	11	4	14	6	16	8	21	13	26	18
	60	21	13	-	-	-	-	-	-	-	-	-	-	11	2	13	4	18	9	23	14
RPES 40	10	7	4	22	19	26	24	31	28	36	33	40	37	45	42	49	46	58	55	67	64
	20	13	8	17	12	22	16	26	21	31	25	35	30	40	34	44	39	53	48	62	57
	30	20	12	12	4	17	9	21	13	26	18	31	22	35	27	40	31	49	40	58	49
	40	26	17	-	-	12	1	17	6	21	10	26	15	30	19	35	24	44	33	53	42
	50	33	21	-	-	-	-	-	-	17	3	21	7	26	12	30	16	39	25	48	34
	60	39	25	-	-	-	-	-	-	-	-	-	-	21	4	25	9	34	18	43	27
RPES 65	10	10	6	33	29	40	36	47	43	54	50	61	57	68	63	75	70	88	84	102	98
	20	20	13	26	17	33	24	40	31	47	38	53	45	60	52	67	59	81	72	95	86
	30	31	19	19	5	25	12	32	19	39	26	46	33	53	40	60	47	74	61	87	74
	40	41	26	-	-	-	-	25	8	32	14	39	21	46	28	52	35	66	49	80	63
	50	51	32	-	-	-	-	-	-	24	3	31	10	38	17	45	23	59	37	73	51
	60	61	39	-	-	-	-	-	-	-	-	-	-	31	5	38	12	52	25	65	39
RPES 100	10	15	9	49	43	60	53	70	64	80	74	90	84	100	94	111	104	131	125	151	145
	20	30	19	39	26	49	36	59	47	69	57	79	67	90	77	100	87	120	108	141	128
	30	44	28	28	9	38	19	48	30	59	40	69	50	79	60	89	70	109	91	130	111
	40	59	37	-	-	27	2	38	13	48	23	58	33	68	43	78	53	99	74	119	94
	50	74	47	-	-	-	-	-	-	37	6	47	16	57	26	68	36	88	57	108	77
	60	89	56	-	-	-	-	-	-	-	-	-	-	47	9	57	19	77	40	98	60
RPES 150	10	24	15	79	69	96	86	112	102	128	118	145	135	161	151	177	167	210	200	243	233
	20	47	30	62	42	79	59	95	75	111	91	128	108	144	124	160	140	193	173	226	206
	30	71	44	45	15	62	32	78	48	94	64	111	81	127	97	143	113	176	146	209	179
	40	94	59	-	-	45	5	61	21	77	37	94	54	110	70	126	86	159	119	192	152
	50	118	74	-	-	-	-	-	-	60	10	77	26	93	43	109	59	142	92	175	124
	60	141	89	-	-	-	-	-	-	-	-	-	-	76	16	92	32	125	65	158	97
RPES 200	10	33	21	108	94	131	117	153	139	175	161	198	184	220	206	242	228	287	273	332	318
	20	65	41	85	57	107	79	129	102	152	124	174	146	196	169	219	191	263	236	308	280
	30	98	62	61	19	83	42	106	64	128	86	150	109	173	131	195	153	240	198	284	243
	40	131	82	-	-	-	-	82	26	104	49	127	71	149	93	171	116	216	161	261	205
	50	163	103	-	-	-	-	-	-	81	11	103	34	125	56	148	78	192	123	237	168
	60	196	124	-	-	-	-	-	-	-	-	-	-	102	18	124	41	169	85	213	130
RPES 350	10	56	35	189	165	227	204	266	243	305	281	344	320	383	359	422	398	499	476	577	553
	20	112	70	148	101	187	139	226	178	265	217	303	256	342	295	381	334	459	411	537	489
	30	168	106	108	36	146	75	185	114	224	153	263	192	302	231	341	269	418	347	496	425
	40	224	141	-	-	106	11	145	50	184	89	222	127	261	166	300	205	378	283	455	360
	50	280	176	-	-	-	-	-	-	143	24	182	63	221	102	260	141	337	218	415	296
	60	335	211	-	-	-	-	-	-	-	-	-	-	180	38	219	77	297	154	374	232
RPES 600	10	96	60	320	279	386	345	452	411	518	477	584	543	650	609	716	675	848	807	980	939
	20	192	121	251	169	317	235	383	301	449	367	515	433	581	499	647	565	779	697	911	829
	30	287	181	181	59	247	125	313	191	379	257	445	323	511	389	577	455	709	587	841	719
	40	383	241	-	-	178	15	244	81	310	147	376	213	442	279	508	345	640	477	772	609
	50	479	302	-	-	-	-	-	-	241	37	307	103	373	169	439	235	571	367	703	499
	60	575	362	-	-	-	-	-	-	-	-	-	-	303	59	369	125	501	257	633	389

Actuator Torque - Spring-Return (Nm)

Actuator Size	Spring set in.	Spring Stroke Torque (Nm)		Air Torque (Nm)																	
				SUPPLY PRESSURE																	
				3.0 barg		3.5 barg		4.0 barg		4.5 barg		5.0 barg		5.5 barg		6.0 barg		7.0 barg		8.0 barg	
Start	End	Start	End	Start	End	Start	End	Start	End	Start	End	Start	End	Start	End	Start	End	Start	End		
RPES 950	10	121	77	481	427	579	525	677	623	775	721	873	819	971	917	1069	1015	1265	1211	1461	1407
	20	242	155	385	276	483	374	581	472	679	570	777	668	875	766	973	864	1169	1060	1365	1256
	30	363	232	288	125	386	223	484	321	582	418	680	516	778	614	876	712	1072	908	1268	1104
	40	484	309	-	-	289	71	387	169	485	267	583	365	681	463	779	561	975	757	1171	953
	50	605	387	-	-	-	-	-	-	389	116	487	214	585	312	683	410	879	606	1075	802
	60	726	464	-	-	-	-	-	-	-	-	390	63	488	161	586	259	782	455	978	651
RPES 1600	10	207	129	808	710	972	874	1136	1038	1300	1202	1465	1367	1629	1531	1793	1695	2122	2023	2450	2352
	20	415	258	647	450	811	615	975	779	1139	943	1304	1107	1468	1271	1632	1436	1960	1764	2289	2093
	30	622	387	486	191	650	355	814	520	978	684	1142	848	1307	1012	1471	1176	1799	1505	2128	1833
	40	830	516	-	-	489	96	653	260	817	425	981	589	1146	753	1310	917	1638	1246	1967	1574
	50	1037	644	-	-	-	-	-	-	656	165	820	330	984	494	1149	658	1477	986	1806	1315
	60	1244	773	-	-	-	-	-	-	-	-	659	70	823	234	988	399	1316	727	1644	1056
RPES 2500	10	295	180	1276	1133	1530	1388	1785	1642	2039	1896	2294	2151	2548	2405	2803	2660	3312	3169	3820	3678
	20	589	361	1050	765	1305	1019	1559	1274	1814	1528	2068	1783	2323	2037	2577	2292	3086	2801	3595	3309
	30	884	541	825	397	1079	651	1334	905	1588	1160	1843	1414	2097	1669	2352	1923	2860	2432	3369	2941
	40	1178	722	-	-	854	283	1108	537	1363	792	1617	1046	1871	1301	2126	1555	2635	2064	3144	2573
	50	1473	902	-	-	-	-	883	169	1137	423	1391	678	1646	932	1900	1187	2409	1696	2918	2205
	60	1768	1083	-	-	-	-	-	-	911	55	1166	310	1420	564	1675	819	2184	1327	2693	1836
RPES 4000	10	473	299	2063	1846	2476	2259	2889	2672	3302	3085	3715	3498	4128	3911	4541	4324	5367	5150	6193	5976
	20	945	598	1690	1255	2103	1668	2516	2081	2929	2494	3342	2907	3755	3320	4168	3733	4994	4559	5820	5385
	30	1418	896	1316	664	1729	1077	2142	1490	2555	1903	2968	2316	3381	2729	3794	3142	4620	3968	5446	4794
	40	1891	1195	943	73	1356	486	1769	899	2182	1312	2595	1725	3008	2138	3421	2551	4247	3377	5073	4203
	50	2363	1494	-	-	-	-	1395	309	1808	722	2221	1135	2634	1548	3047	1961	3873	2787	4699	3613
	60	2836	1793	-	-	-	-	-	-	1435	131	1848	544	2261	957	2674	1370	3500	2196	4326	3022

Notes:

- Emerson recommends that the valve manufacturer supply the maximum required torque values (Including any adjustments or suggested safety factors for valve service conditions or application).
- Additionally, the valve manufacturer must identify at which position(s) and direction(s) of rotation (Counterclockwise or Clockwise) these maximum requirements occur.
- If in doubt, or you require any assistance with sizing actuators, do not hesitate to contact your nearest Emerson's Actuation Technologies Division representative.

Figure 1. Spring-Return torque diagram

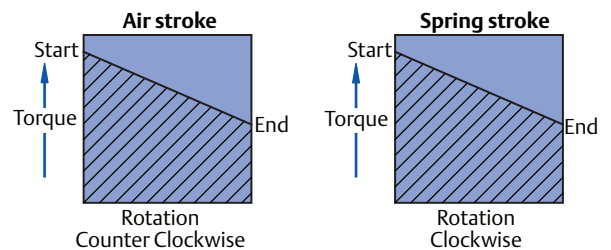

Actuator Torque - Spring-Return (lbf.in)

Actuator Size	Spring set nr.	Spring Stroke Torque (lbf.in)		Air Stroke Torque (lbf.in)															
				SUPPLY PRESSURE															
		Start	End	40 psig		50 psig		60 psig		70 psig		80 psig		90 psig		100 psig		120 psig	
RPES 25	10	31	20	93	80	123	109	152	139	181	168	211	198	240	227	270	257	329	316
	20	63	39	70	44	100	73	129	103	159	132	188	162	218	191	247	221	306	280
	30	94	59	48	8	77	37	107	67	136	96	166	126	195	155	225	185	283	244
	40	125	79	-	-	-	-	84	31	113	60	143	90	172	119	202	149	261	208
	50	156	99	-	-	-	-	-	-	91	24	120	54	150	83	179	113	238	172
	60	188	118	-	-	-	-	-	-	-	-	98	18	127	47	157	77	216	136
RPES 40	10	58	37	175	150	230	206	285	261	341	316	396	371	451	427	506	482	617	592
	20	116	73	133	84	188	139	243	195	299	250	354	305	409	360	464	415	575	526
	30	174	110	91	18	146	73	201	128	257	183	312	239	367	294	422	349	533	459
	40	231	146	-	-	-	-	159	62	214	117	270	172	325	227	380	283	491	393
	50	289	183	-	-	-	-	-	-	172	50	228	106	283	161	338	216	449	327
	60	347	220	-	-	-	-	-	-	-	-	186	39	241	94	296	150	407	260
RPES 65	10	90	57	265	227	349	311	434	395	518	479	602	564	686	648	770	732	939	900
	20	181	114	200	123	284	207	368	291	452	376	537	460	621	544	705	628	873	796
	30	271	171	134	19	219	103	303	188	387	272	471	356	555	440	639	524	808	693
	40	361	228	-	-	-	-	237	84	322	168	406	252	490	336	574	420	742	589
	50	452	285	-	-	-	-	-	-	256	64	340	148	424	232	509	317	677	485
	60	542	341	-	-	-	-	-	-	-	-	275	44	359	129	443	213	612	381
RPES100	10	131	83	394	339	518	463	643	588	767	712	892	836	1016	961	1141	1085	1390	1334
	20	262	166	299	188	423	313	548	437	672	562	797	686	921	811	1046	935	1295	1184
	30	392	248	203	38	328	162	452	287	577	411	701	536	826	660	950	785	1199	1034
	40	523	331	-	-	-	-	357	136	482	261	606	385	731	510	855	634	1104	883
	50	654	414	-	-	-	-	-	-	387	110	511	235	636	359	760	484	1009	733
	60	785	497	-	-	-	-	-	-	-	-	416	85	540	209	665	334	914	583
RPES 150	10	208	131	633	544	832	743	1031	942	1231	1142	1430	1341	1629	1540	1829	1740	2227	2138
	20	416	262	482	304	681	504	881	703	1080	902	1279	1102	1479	1301	1678	1500	2077	1899
	30	625	393	332	65	531	264	730	464	930	663	1129	862	1328	1062	1528	1261	1926	1660
	40	833	524	-	-	-	-	580	224	779	424	979	623	1178	823	1377	1022	1776	1421
	50	1041	654	-	-	-	-	-	-	629	185	828	384	1027	583	1227	783	1626	1181
	60	1249	785	-	-	-	-	-	-	-	-	678	145	877	344	1076	543	1475	942
RPES 200	10	289	182	862	739	1135	1012	1408	1285	1681	1558	1954	1831	2226	2104	2499	2376	3045	2922
	20	578	364	653	407	926	680	1198	953	1471	1226	1744	1499	2017	1771	2290	2044	2836	2590
	30	867	547	443	75	716	348	989	621	1262	894	1535	1166	1808	1439	2080	1712	2626	2258
	40	1156	729	-	-	-	-	780	289	1052	561	1325	834	1598	1107	1871	1380	2417	1926
	50	1445	911	-	-	-	-	-	-	843	229	1116	502	1389	775	1662	1048	2207	1593
	60	1734	1093	-	-	-	-	-	-	-	-	906	170	1179	443	1452	716	1998	1261
RPES 350	10	495	312	1503	1293	1978	1767	2452	2241	2926	2716	3400	3190	3874	3664	4348	4138	5296	5086
	20	990	624	1145	724	1619	1199	2093	1673	2567	2147	3041	2621	3515	3095	3990	3569	4938	4517
	30	1485	936	786	156	1261	630	1735	1104	2209	1578	2683	2052	3157	2526	3631	3000	4579	3948
	40	1979	1248	-	-	-	-	1376	535	1850	1009	2324	1483	2798	1957	3272	2431	4221	3380
	50	2474	1560	-	-	-	-	-	-	1492	440	1966	914	2440	1388	2914	1863	3862	2811
	60	2969	1872	-	-	-	-	-	-	-	-	1607	346	2081	820	2555	1294	3504	2242
RPES 600	10	848	534	2551	2190	3356	2996	4162	3801	4968	4607	5773	5413	6579	6218	7385	7024	8996	8635
	20	1695	1068	1937	1216	2743	2021	3548	2827	4354	3633	5160	4438	5965	5244	6771	6050	8382	7661
	30	2543	1601	1324	241	2129	1047	2935	1853	3741	2658	4546	3464	5352	4270	6158	5075	7769	6687
	40	3391	2135	-	-	-	-	2321	878	3127	1684	3933	2490	4738	3295	5544	4101	7155	5712
	50	4238	2669	-	-	-	-	-	-	2513	710	3319	1515	4125	2321	4930	3127	6542	4738
	60	5086	3203	-	-	-	-	-	-	-	-	2706	541	3511	1346	4317	2152	5928	3763

Actuator Torque - Spring-Return (lbf.in)

Actuator Size	Spring setnr.	Spring Stroke Torque (lbf.in)		Air Stroke Torque (lbf.in)															
				SUPPLY PRESSURE															
		Start	End	40 psig		50 psig		60 psig		70 psig		80 psig		90 psig		100 psig		120 psig	
RPES 950	10	1070	685	3842	3360	5038	4556	6234	5752	7430	6948	8627	8144	9823	9340	11019	10536	13411	12929
	20	2141	1369	2986	2022	4182	3218	5379	4414	6575	5610	7771	6806	8967	8002	10163	9198	12555	11591
	30	3211	2054	2130	683	3327	1880	4523	3076	5719	4272	6915	5468	8111	6664	9307	7860	11699	10252
	40	4282	2738	-	-	2471	541	3667	1738	4863	2934	6059	4130	7255	5326	8451	6522	10844	8914
	50	5352	3423	-	-	-	-	2811	399	4007	1596	5203	2792	6400	3988	7596	5184	9988	7576
	60	6423	4108	-	-	-	-	-	-	3152	257	4348	1454	5544	2650	6740	3846	9132	6238
RPES 1600	10	1835	1141	6447	5579	8452	7583	10456	9588	12461	11592	14466	13597	16470	15602	18475	17606	22484	21615
	20	3671	2281	5022	3284	7026	5289	9031	7294	11035	9298	13040	11303	15044	13307	17049	15312	21058	19321
	30	5506	3422	3596	990	5600	2995	7605	4999	9610	7004	11614	9008	13619	11013	15623	13018	19632	17027
	40	7342	4562	-	-	4175	700	6179	2705	8184	4709	10188	6714	12193	8719	14198	10723	18207	14732
	50	9177	5703	-	-	-	-	4753	411	6758	2415	8763	4420	10767	6424	12772	8429	16781	12438
	60	11013	6844	-	-	-	-	-	-	-	-	7337	2125	9342	4130	11346	6135	15355	10144
RPES 2500	10	2607	1597	10204	8941	13310	12047	16416	15153	19523	18259	22629	21366	25735	24472	28841	27578	35054	33791
	20	5215	3194	8208	5681	11314	8788	14420	11894	17526	15000	20633	18106	23739	21213	26845	24319	33058	30532
	30	7822	4791	6211	2422	9318	5528	12424	8635	15530	11741	18636	14847	21743	17953	24849	21060	31062	27272
	40	10430	6388	-	-	7321	2269	10428	5375	13534	8482	16640	11588	19747	14694	22853	17800	29065	24013
	50	13037	7985	-	-	-	-	8432	2116	11538	5222	14644	8329	17750	11435	20857	14541	27069	20754
	60	15645	9582	-	-	-	-	-	-	9542	1963	12648	5069	15754	8176	18860	11282	25073	17494
RPES 4000	10	4183	2645	16495	14572	21537	19613	26578	24655	31620	29696	36661	34738	41703	39780	46744	44821	56828	54904
	20	8366	5289	13189	9343	18231	14384	23273	19426	28314	24467	33356	29509	38397	34550	43439	39592	53522	49675
	30	12550	7934	9884	4114	14925	9155	19967	14197	25008	19238	30050	24280	35092	29321	40133	34363	50216	44446
	40	16733	10578	-	-	11620	3926	16661	8968	21703	14009	26744	19051	31786	24092	36827	29134	46911	39217
	50	20916	13223	-	-	-	-	13355	3739	18397	8780	23439	13822	28480	18863	33522	23905	43605	33988
	60	25099	15867	-	-	-	-	-	-	15091	3551	20133	8593	25174	13634	30216	18676	40299	28759

Notes:

- Emerson recommends that the valve manufacturer supply the maximum required torque values (Including any adjustments or suggested safety factors for valve service conditions or application).
- Additionally, the valve manufacturer must identify at which position(s) and direction(s) of rotation (Counter Clock Wise or Clock Wise) these maximum requirements occur.
- If in doubt, or if you require any assistance with sizing actuators, do not hesitate to contact your nearest Emerson's Actuation Technologies Division representative.

Figure 1. Spring Return torque diagram

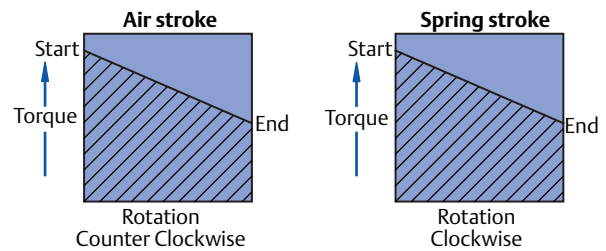

Actuator Torque - Double-Acting (Nm)

Actuator Size	Torque in Nm Supply Pressure (barg)										
	2	3	3.5	4	4.5	5	5.5	6	6.5	7	8
RPED 25	9	13	16	18	20	23	25	27	29	32	36
RPED 40	17	25	29	34	38	42	47	51	55	59	68
RPED 65	25	38	45	51	58	64	71	77	84	90	103
RPED 100	38	57	66	76	86	95	105	115	124	134	153
RPED 150	60	91	106	122	137	153	168	183	199	214	245
RPED 200	82	124	146	167	188	209	230	251	272	293	335
RPED 350	143	216	253	290	326	363	400	436	473	510	583
RPED 600	243	368	430	492	554	617	679	741	804	866	991
RPED 950	368	557	651	746	840	935	1029	1124	1218	1312	1501
RPED 1600	617	934	1092	1250	1408	1566	1725	1883	2041	2199	2516
RPED 2500	956	1447	1692	1937	2182	2427	2673	2918	3163	3408	3899
RPED 4000	1552	2348	2746	3144	3542	3940	4338	4736	5134	5532	6327

Notes:

1. Emerson recommends that the valve manufacturer supply the maximum required torque values (Including any adjustments or suggested safety factors for valve service conditions or application).
2. Additionally, the valve manufacturer must identify at which position(s) and direction(s) of rotation (Counter Clock Wise or Clock Wise) these maximum requirements occur.
3. If in doubt, or if you require any assistance with sizing actuators, do not hesitate to contact your nearest Emerson's Actuation Technologies Division representative.

Figure 1. Double acting torque diagram

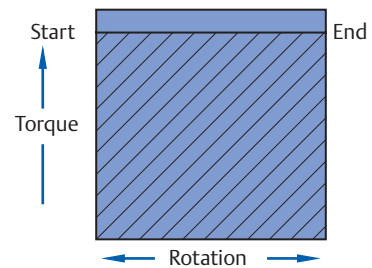

Actuator Torque - Double-Acting (lbf.in)

Actuator Size	Torque in lbf.in Supply pressure (psig)												
	30	35	40	45	50	55	60	70	75	80	90	100	120
RPED 25	81	95	109	123	137	151	165	193	207	220	248	276	332
RPED 40	153	179	205	231	257	283	309	361	387	413	466	518	622
RPED 65	233	272	312	352	392	431	471	550	590	630	709	789	948
RPED 100	344	403	461	520	579	638	696	814	873	931	1049	1166	1401
RPED 150	551	645	739	833	927	1021	1115	1304	1398	1492	1680	1868	2244
RPED 200	754	883	1011	1140	1269	1398	1527	1784	1913	2042	2299	2557	3072
RPED 350	1310	1534	1758	1981	2205	2429	2653	3100	3324	3547	3995	4442	5337
RPED 600	2226	2606	2987	3367	3747	4127	4508	5268	5648	6028	6789	7549	9070
RPED 950	3374	3950	4527	5103	5679	6255	6832	7984	8560	9137	10289	11442	13747
RPED 1600	5654	6620	7586	8552	9517	10483	11449	13380	14346	15312	17243	19175	23038
RPED 2500	8762	10259	11755	13252	14748	16245	17741	20734	22231	23727	26720	29713	35699
RPED 4000	14221	16650	19079	21508	23937	26365	28794	33652	36081	38510	43368	48225	57941

Notes:

1. Emerson recommends that the valve manufacturer supply the maximum required torque values (Including any adjustments or suggested safety factors for valve service conditions or application).
2. Additionally, the valve manufacturer must identify at which position(s) and direction(s) of rotation (Counter Clock Wise or Clock Wise) these maximum requirements occur.
3. If in doubt, or if you require any assistance with sizing actuators, do not hesitate to contact your nearest Emerson's Actuation Technologies Division representative.

Figure 2. Double acting torque diagram

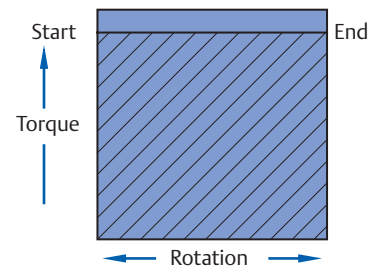

Sizing of Rack & Pinion actuators

Sizing is the selection procedure to select the right size of actuator on a valve with a given torque characteristic. This data sheet gives brief samples on how to size actuators and which data is needed.

Torque characteristics of valves

Bettis RPE-Series actuators are commonly used to operate butterfly-, ball- and plug valves. The below instructions are intended for these valve applications, but can also be used for other quarter turn applications.

Figure 1. Generic torque characteristic of a valve

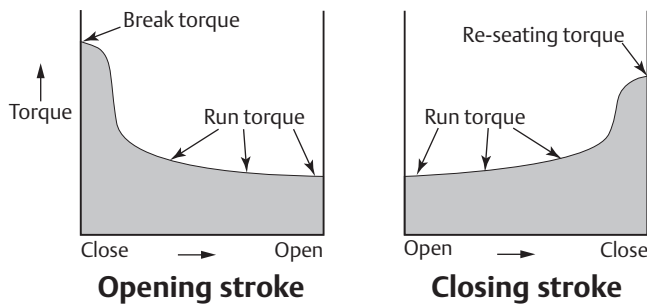

Valve torque values and safety factors

Emerson recommends that the valve manufacturer supply the maximum required and allowed torque values (Including any adjustments or suggested safety factors for valve service conditions or application).

Additionally, the valve manufacturer must identify at which position(s) and direction(s) of rotation (Counterclockwise or Clockwise) these maximum requirements occur.

If in doubt, or you require any assistance with sizing actuators, do not hesitate to contact your nearest Emerson's Valve Automation representative.

Sizing Double-Acting actuators

Figure 2. Double-Acting torque characteristic

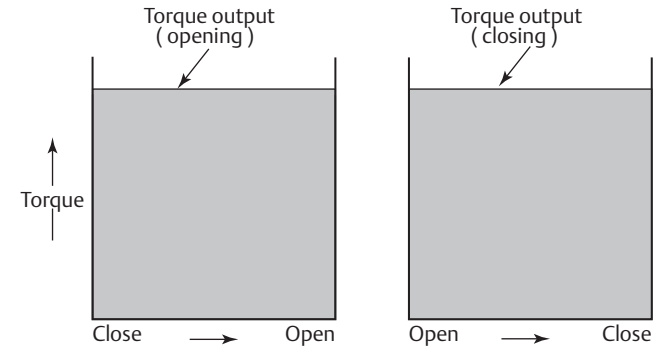

Sample calculation of Double-Acting sizing

- Publish valve break torque: 40 Nm 354 lbf.in
- Publish maximum stem torque: 105 Nm 929 lbf.in
- Recommended safety factor: 1.2 (20%)
- Minimum supply pressure: 5.5 bar 80 psi
- Maximum supply pressure: 6.5 bar 94 psi

Calculation:

1. Because the recommended safety factor is 1.2 the sizing torque will be $40 \times 1.2 = 48 \text{ Nm}$ ($354 \times 1.2 = 425 \text{ lbf.in}$).
2. Lookup in the Double-Acting torque table, in the 5.5 bar column (or 80 psi column), from top down, the first actuator size that generates more than 48 Nm (or 425 lbf.in).
3. Size RPED65 is the first actuator that supplies more than
 - a. 48 Nm (71 Nm) at 5.5 bar.
 - b. 425 lbf.in (630 lbf.in.) at 80 PSI.
4. The maximum torque output of a RPED65 is 84 Nm (743 lbf.in). This is lower than the maximum stem torque of 105Nm.

Conclusion

Because RPED65 supplies more torque than the sizing torque (see point 3) and less than the maximum stem torque (see point 4), size RPED65 is suitable to operate this valve.

Sizing Spring-Return actuators

Figure 3. Spring-to-Close configuration

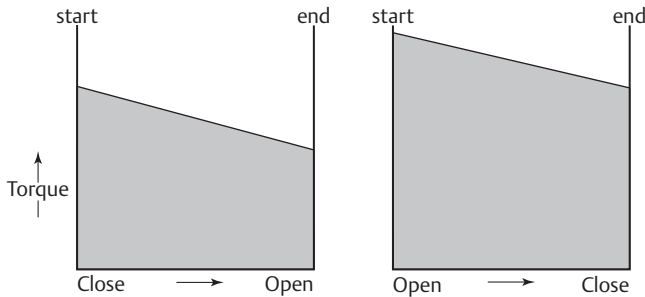

Table 1. For Fail-to Close actuators applies:

Actuator stroke:	Valve Stroke:
Air-Start torque	> Break torque and
Air-End torque	> Run open torque and
Spring-Start torque	> Run open torque and
Spring-End torque	> Re-seat torque

Table 2. For Fail-to Open actuators applies:

Actuator stroke:	Valve Stroke:
Spring-Start torque	> Break torque and
Spring-End torque	> Run torque and
Air-Start torque	> Run torque and
Air-End torque	> Re-seat torque

Sample calculation Spring-Return sizing for a Spring-to-Close application

- Published valve torques
 - Break torque: 150 Nm 1328 lbf.in
 - Run torque opening: 45 Nm 398 lbf.in
 - Run torque closing: 45 Nm 398 lbf.in
 - Re-seating torque; 90 Nm 797 lbf.in
- Publish maximum stem torque: 375 Nm 3496 lbf.in
- Recommended safety factor: 1.5 (50%)
- Minimum supply pressure: 5.5 bar 80 psi
- Maximum supply pressure: 6.0 bar 87 psi

Calculation:

1. Because the recommended safety factor is 1.5 the sizing torques will be:
 - Break 150 Nm x 1.5 = 225 Nm 1991 lbf.in
 - Run open 45 Nm x 1.5 = 67.5 Nm 597 lbf.in
 - Run close 45 Nm x 1.5 = 67.5 Nm 597 lbf.in
 - Re-seat 90 Nm x 1.5 = 135 Nm 1195 lbf.in
2. Lookup in the Spring-Return torque table, in the "spring end" torque column, from top down, the first actuator size that generates more than 135 Nm (or 1195 lbf.in) of re-seat torque.
3. Size RPES350 with spring set 4 is the first actuator that supplies more spring end torque (149 Nm or 1655 lbf.in).
4. Check now for the other three positions whether the actuator torque exceeds the valve torques.

Actuator stroke:	Valve Stroke:
Air-Start: 252 Nm	> Break open: 225 Nm.
Air-End: 157 Nm	> Run open: 67.5 Nm.
Spring-Start: 232 Nm	> Run close: 67.5 Nm.
Spring-End: 149 Nm	> Re-seat: 135 Nm

5. The maximum torque output of a RPES350 with springset 4 at maximum pressure of 6 bar is 291 Nm (2575 lbf.in). This is lower than the maximum stem torque of 375 Nm (3496 lbf.in).

Conclusion

Because RPES350 n=40 supplies more torque than the sizing torque (see point 3) and less than the maximum stem torque (see point 5), size RPES350 n=40 is suitable to operate this valve.

Notes:

- If the first found actuator does not exceed the valve torque at all the positions, check the next size actuator.
- If the next size actuator does exceed the valve torque at all the positions, but fails at maximum stem torque check whether the same actuator but with a higher springset (i.e. 50 instead of 40) does meet this requirement.

Spring (Cartridge) placement

Bettis RPE-Series Spring return actuators are supplied with springs on each side of the actuator. Throughout the RPE-Series size range, there are two different spring designs:

- Sizes RPE25 to RPE600 have 6 springs on each side (see figure 1).
- Sizes RPE950 to RPE4000 have 3 springs on each side (see figure 2).

Check below figures to see where to place the spring cartridges in case of spring set conversion.

When replacing spring cartridges in a spring-return actuator, ensure that the cartridges are replaced in their identical position from where they were removed.

Before assembling the spring cartridges and end caps, make sure that the pistons are completely inwards.

Figure 1. Spring placement sizes RPE25 to RPE600

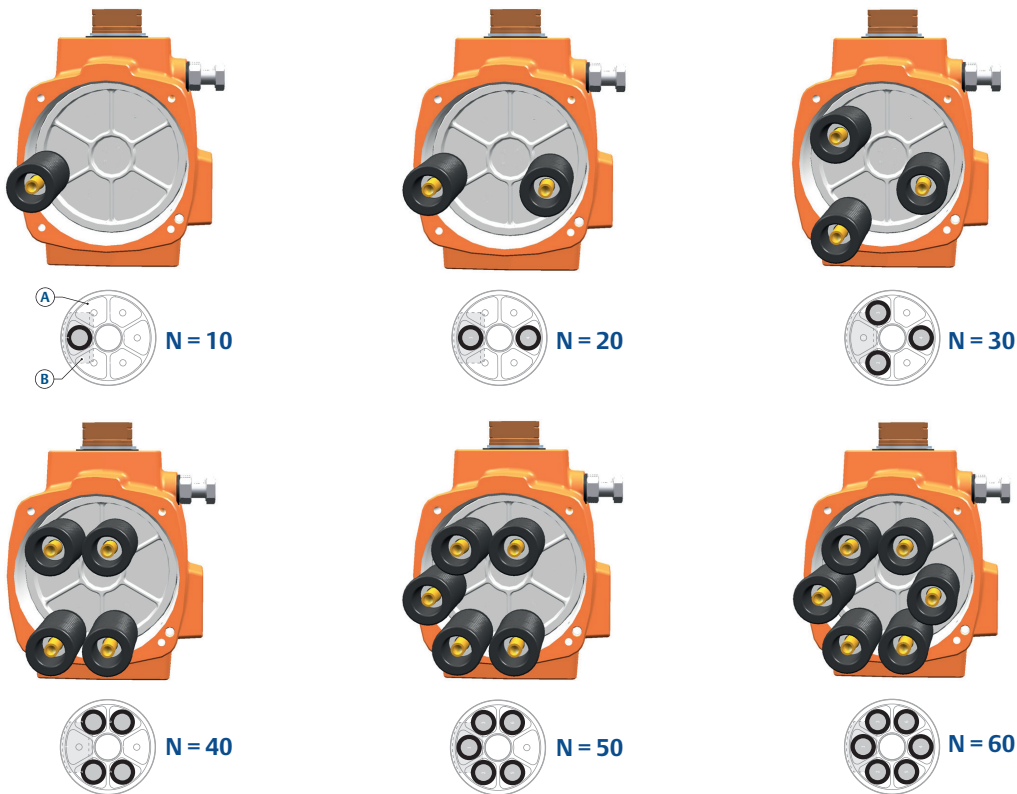

A = Piston top view
B = Position of piston gear rack

Figure 2. Spring placement sizes RPE 950 to RPE4000

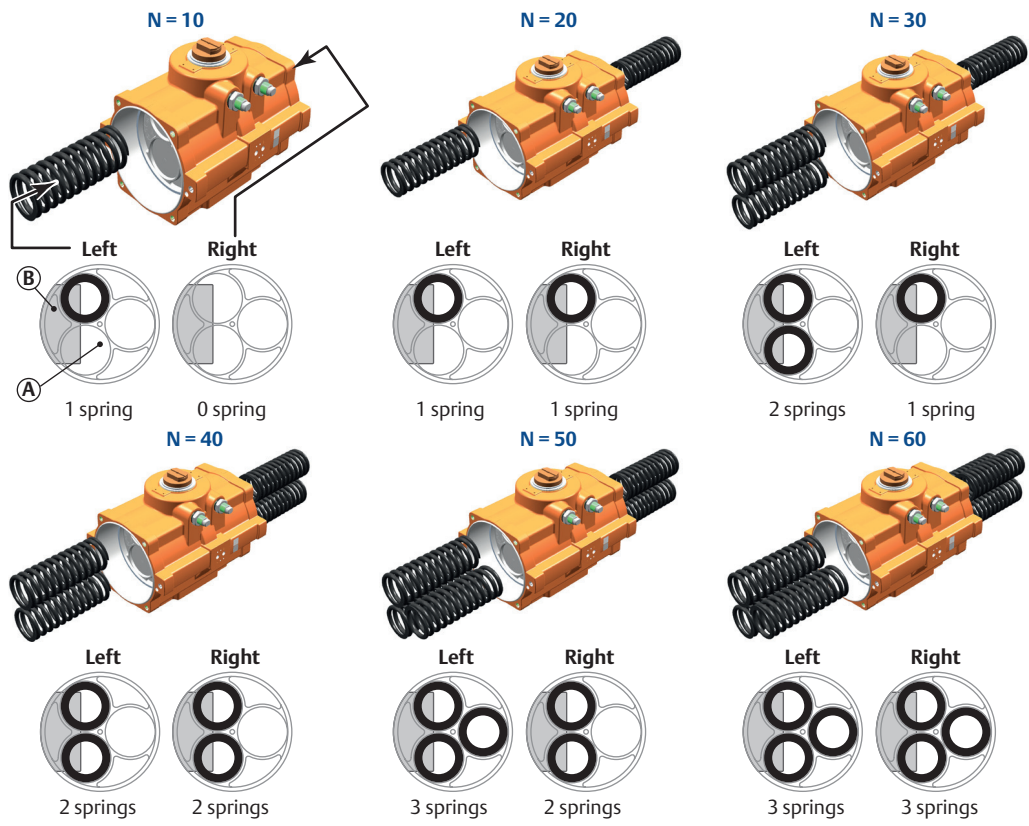

A = Piston top view
 B = Position of piston gear rack

Dimensions - Metric (ISO5211)

Envelope Dimensions - Solenoid and Top Mounting Interface Sizes 25 - 600

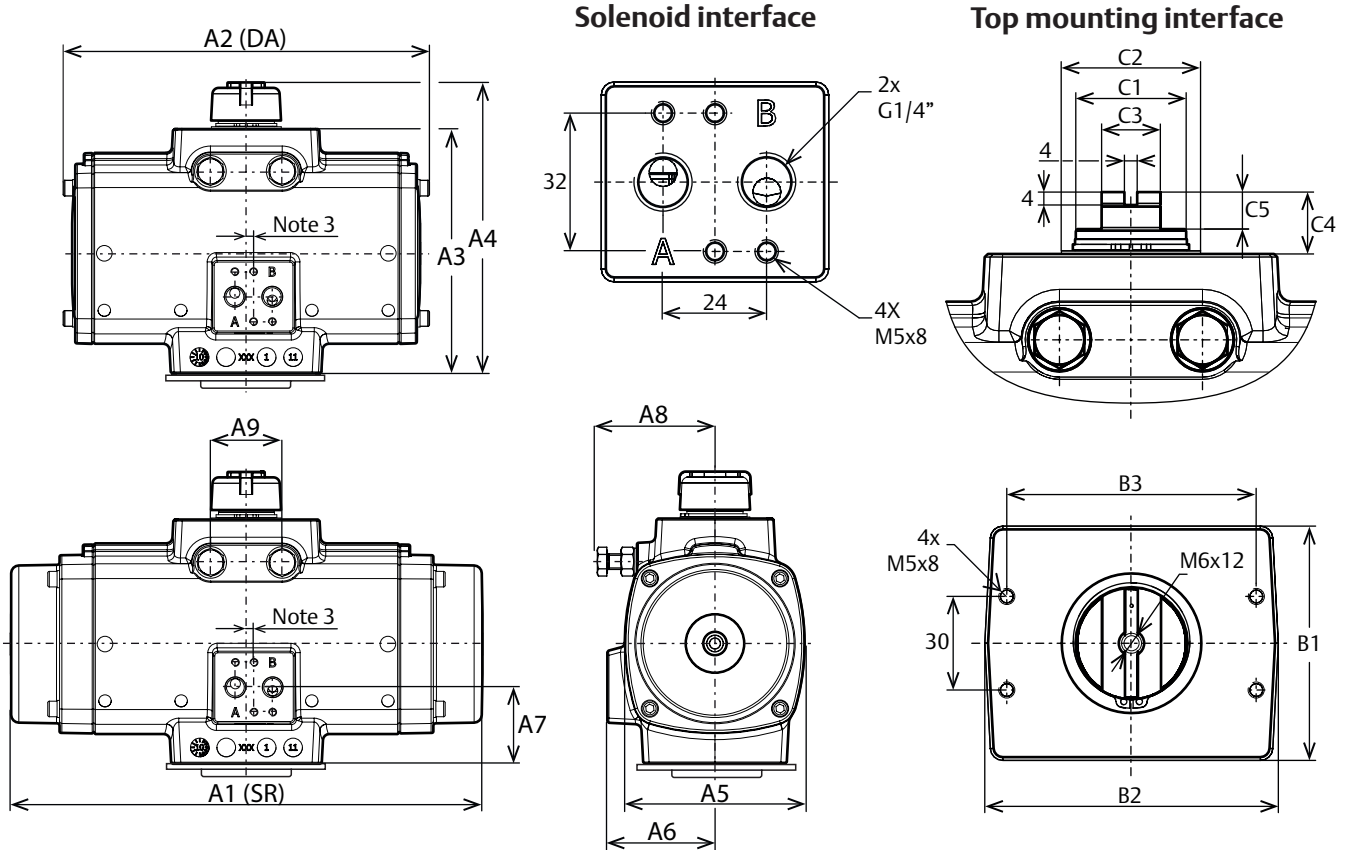

Notes:

1. DA = Double-Acting, SR = Spring-Return
2. Solenoid interface and top mounting interface according to VDI/VDE3845 (NAMUR)
3. The solenoid drilling pattern is shifted 4 mm for size 0025 and 2 mm for size 0040 vs the centerline of the actuator.

Dim in. mm	Actuator size							
	0025	0040	0065	0100	0150	0200	0350	0600
A1	166	192	217	247	304	362	385	476
A2	166	192	217	247	235	265	284	356
A3	91	112	124	131	157	163	201	248
A4	119	139	151	158	185	191	230	292
A5	68	82	92	103	116	124	161	195
A6	49	55	58	64	69	72	85	102
A7	30	34	38	38	49	49	42	67
A8	48	58	69	69	75	87	109	132
A9	18	25	27	28	46	46	46	60
B1	43	45	50	60	75	75	85	98
B2	94	94	94	97	94	94	100	148
B3	80	80	80	80	80	80	80	130
C1	16	22	22	22	34	36	36	55
C2	23	30	30	35	45	45	45	65
C3	14	14	14	14	19	19	19	36
C4	20	20	20	20	20	20	20	30
C5	12	12	12	12	12	12	12	10

Dimensions - Metric (ISO5211)

Envelope Dimensions - Solenoid and Top Mounting Interface Sizes 950 - 4000

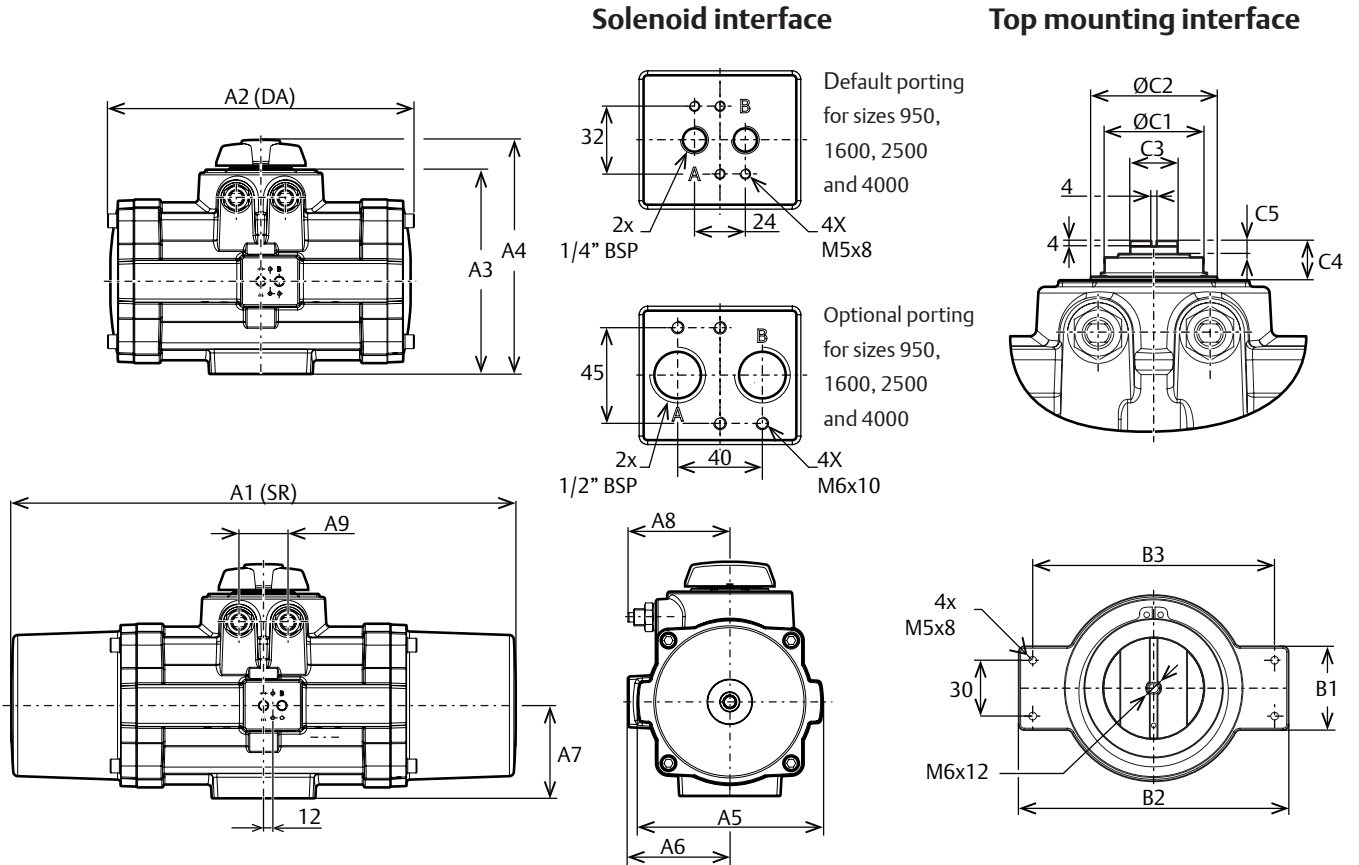

Notes:

1. DA = Double-Acting, SR = Spring-Return
2. Solenoid interface and top mounting interface according to VDI/VDE3845 (NAMUR)
3. The solenoid drilling pattern is shifted 12 mm for sizes 0950 to 4000 vs the centerline of the actuator.
4. The numbers in brackets are for actuators with 1/2" ports.

Dim in. mm	Actuator size			
	0950	1600	2500	4000
A1	658	732	877	959
A2	400	462	550	649
A3	268	302	354	389
A4	305	339	392	427
A5	239	306	350	400
A6	131	149	170	196
A7	121	137 (140) ⁴	157 (160) ⁴	184 (186) ⁴
A8	131	156	181	175
A9	64	85	102	184
B1	45	45	45	45
B2	145	145	145	145
B3	130	130	130	130
C1	65	75	95	96
C2	83	96	115	115
C3	36	36	36	36
C4	30	30	30	30
C5	10	10	10	10

Dimensions - Metric (ISO5211)

Valve Flange and Drive Details Sizes 25 - 4000

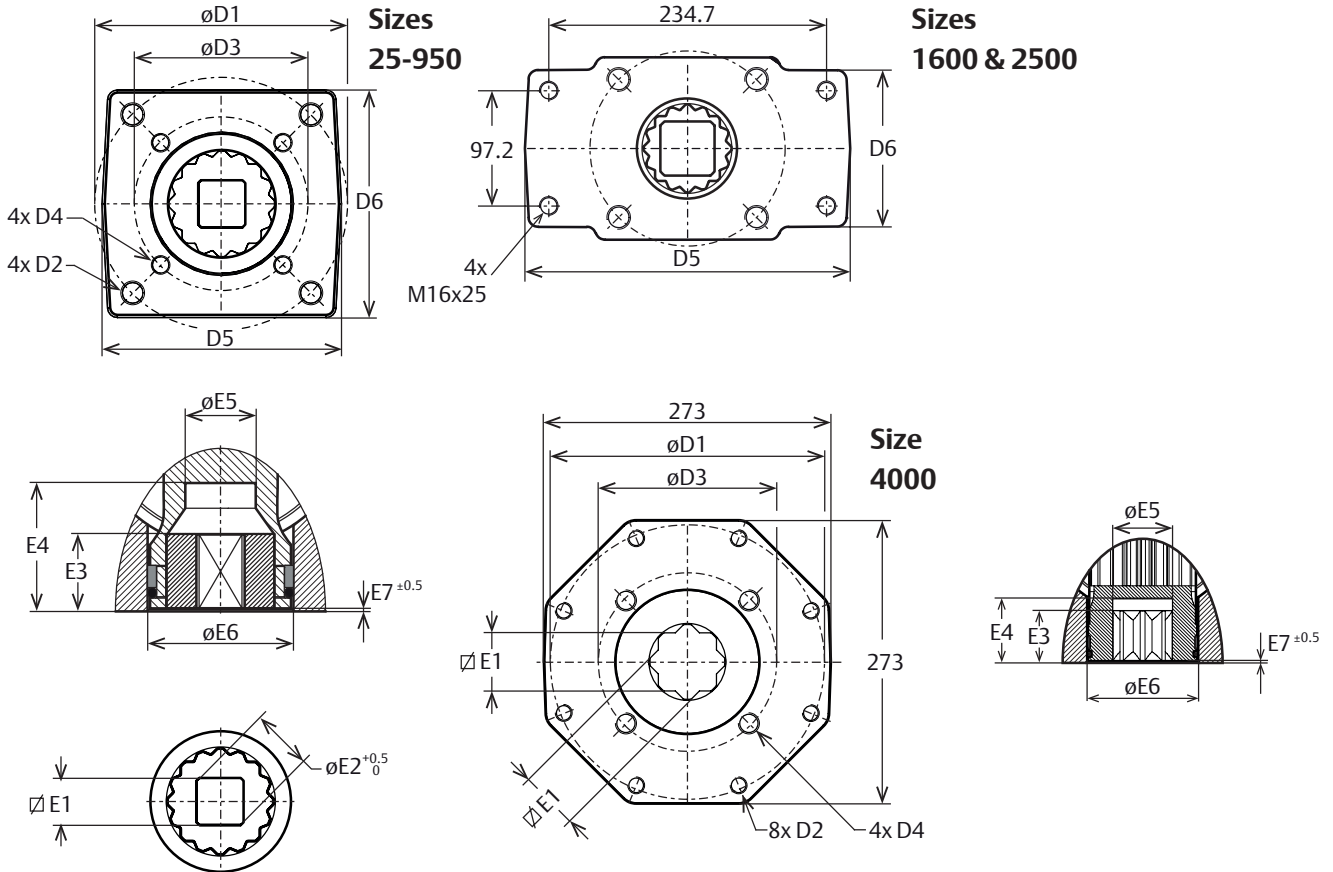

Notes:

1. Flange and square drive according to ISO 5211
2. F25* = For sizes 1600 and 2500 drilling pattern 234.6 x 97.2 represent 4 holes of a F25 drilling pattern.
3. Size 4000 has 2x inner square E1 in the pinion bottom instead of inserts

Dim in.	Actuator size											
mm	0025	0040	0065	0100	0150	0200	0350	0600	0950	1600	2500	4000
ISO 1	F05	F07	F07	F07	F10	F10	F10	F12	F14	F16	F16	F25
D1	50	70	70	70	102	102	102	125	140	165	165	254
D2	M6x10	M8x13	M8x13	M8x13	M10x15	M10x15	M10x15	M12x18	M16x25	M20x20	M20x20	M16x25
ISO 2	F03	F05	F05	F05	F07	F07	F07	F10	F10	F25*	F25*	F16
D3	36	50	50	50	70	70	70	102	102	-/-	-/-	165
D4	M5x8	M6x10	M6x10	M6x10	M8x13	M8x13	M8x13	M10x16	M10x16	-/-	-/-	M20x20
D5	50	68	68	66	97	94	94	118	135	280	280	273
D6	48	65	65	63	92	90	94	113	130	132	132	269
E1 Max.	11.08	14.08	14.08	19.08	19.08	22.10	27.11	27.11	36.16	46.16	46.16	55.24
E1 Min.	11.00	14.00	14.00	19.00	19.00	22.00	27.00	27.00	36.00	46.00	46.00	55.00
E2	14.1	18.1	18.1	25.2	25.5	28.2	36.2	36.2	58.2	60.2	60.2	72.2
E3	15	15	15	18	27.5	27.5	27.5	27.5	48.5	59.5	59.5	61.5
E4	34	34	34	34	50	50	50	50	65.5	81.5	81.5	76.75
E5	14.1	18.1	21.1	23.5	28.5	32.1	32.1	36.5	48	60	60	73
E6	24.5	34.5	34.5	38	56.5	56.5	56.5	67.5	86	104	125	133
E7	0.5	1	1	1	1.2	1.2	1.2	1.2	1	1	1	1

Dimensions - Metric (DIN3337)

Envelope Dimensions - Solenoid and Top Mounting Interface Sizes 25 - 600

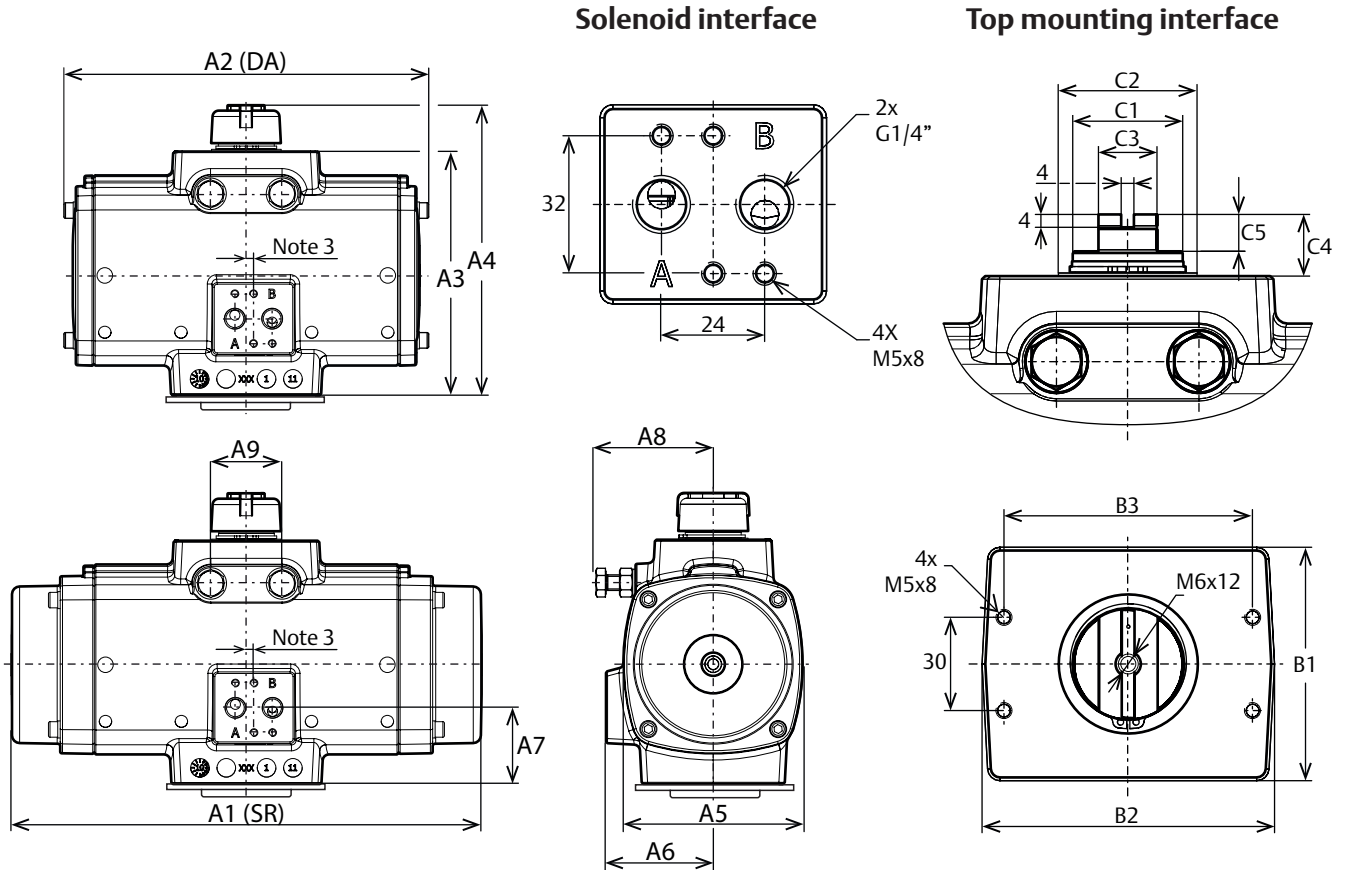

Notes:

1. DA = Double-Acting, SR = Spring-Return
2. Solenoid interface and top mounting interface according to VDI/VDE3845 (NAMUR)
3. The solenoid drilling pattern is shifted 4 mm for size 0025 and 2 mm for size 0040 vs the centerline of the actuator.

Dim in. mm	Actuator size							
	0025	0040	0065	0100	0150	0200	0350	0600
A1	166	192	217	247	304	362	385	476
A2	166	192	217	247	235	265	284	356
A3	91	112	124	131	157	163	201	248
A4	119	139	151	158	185	191	230	292
A5	68	82	92	103	116	124	161	195
A6	49	55	58	64	69	72	85	102
A7	30	34	38	38	49	49	42	67
A8	48	58	69	69	75	87	109	132
A9	18	25	27	28	46	46	46	60
B1	43	45	50	60	75	75	85	98
B2	94	94	94	97	94	94	100	148
B3	80	80	80	80	80	80	80	130
C1	16	22	22	22	34	36	36	55
C2	23	30	30	35	45	45	45	65
C3	14	14	14	14	19	19	19	36
C4	20	20	20	20	20	20	20	30
C5	12	12	12	12	12	12	12	10

Dimensions - Metric (DIN3337)

Envelope Dimensions - Solenoid and Top Mounting Interface Sizes 950 - 4000

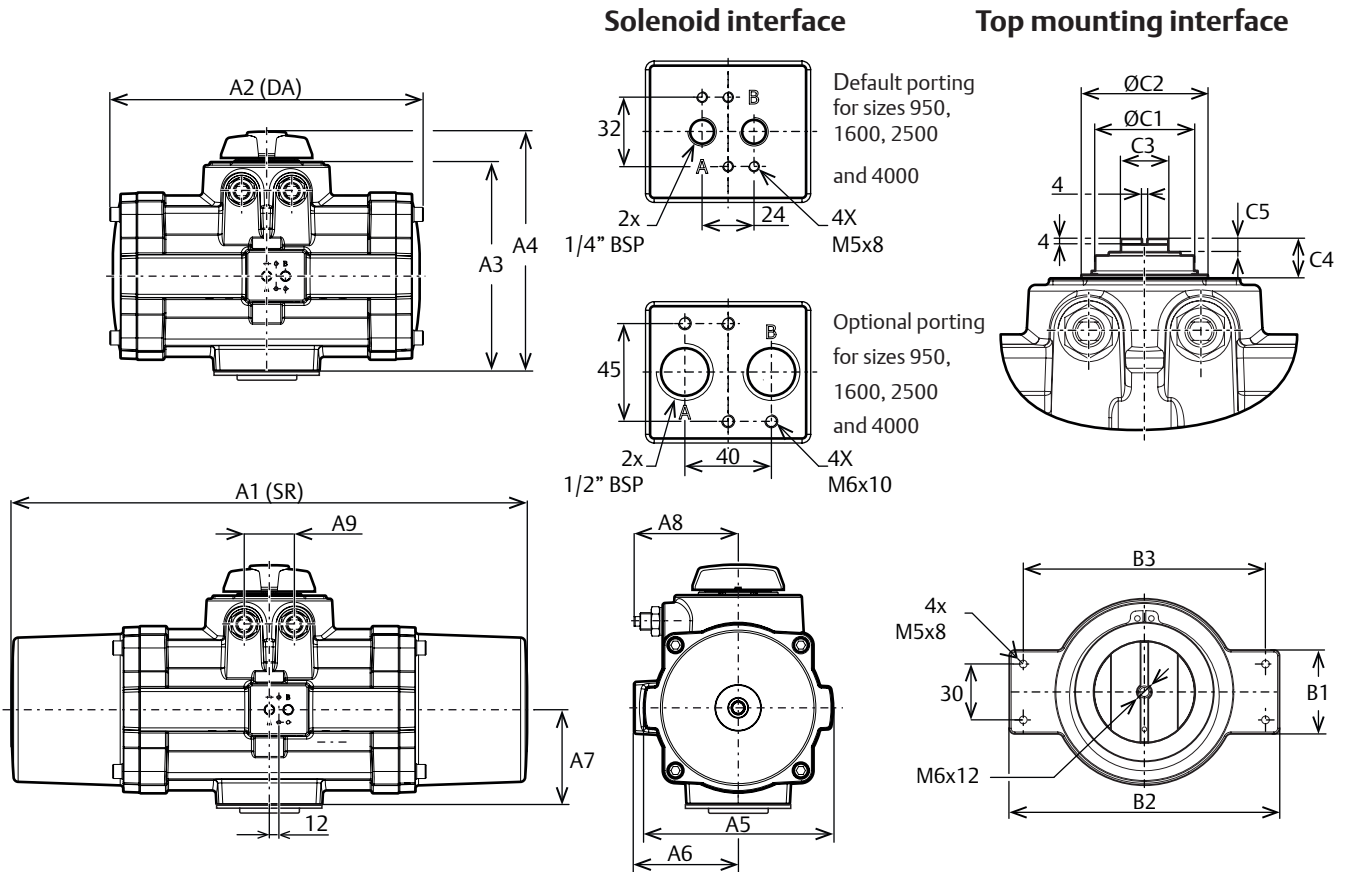

Notes:

1. DA = Double-Acting, SR = Spring-Return
2. Solenoid interface and top mounting interface according to VDI/VDE3845 (NAMUR)
3. The solenoid drilling pattern is shifted 12 mm for sizes 0950 to 4000 vs the centerline of the actuator.
4. The numbers in brackets are for actuators with 1/2" ports.

Dim in.	Actuator size			
mm	0950	1600	2500	4000
A1	658	732	877	959
A2	400	462	550	649
A3	268	302	354	389
A4	305	339	392	427
A5	239	306	350	400
A6	131	149	170	196
A7	121	137 (140) ⁴	157 (160) ⁴	184 (186) ⁴
A8	131	156	181	175
A9	64	85	102	184
B1	45	45	45	45
B2	145	145	145	145
B3	130	130	130	130
C1	65	75	95	96
C2	83	96	115	115
C3	36	36	36	36
C4	30	30	30	30
C5	10	10	10	10

Dimensions - Metric (ISO5211)

Valve Flange and Drive Details Sizes 25 - 4000

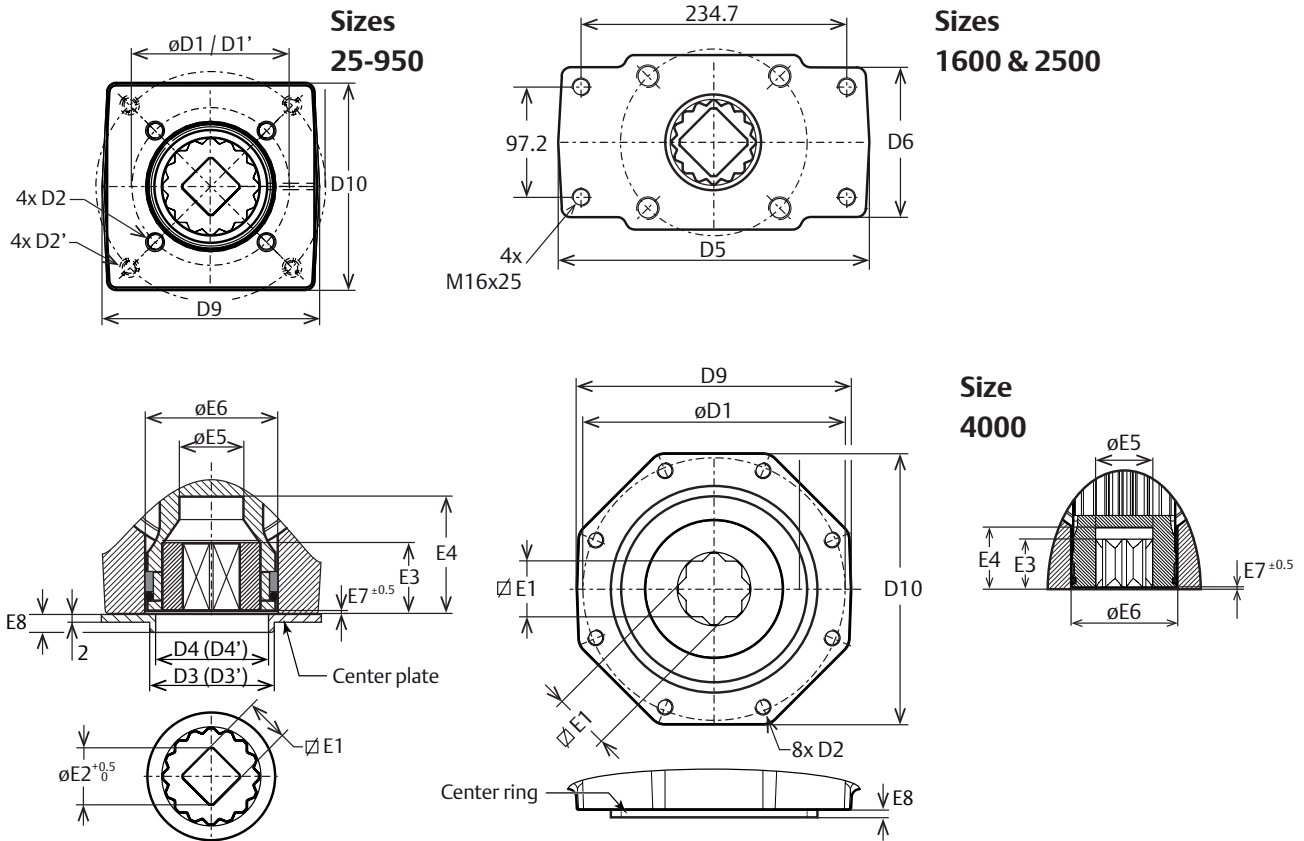

Notes:

1. Flange and square drive according to ISO 5211
2. F25* = For sizes 1600 and 2500 drilling pattern 234.6 x 97.2 represent 4 holes of a F25 drilling pattern.
3. Size 4000 has 2x inner square E1 in the pinion bottom instead of inserts
4. Drilling patterns DIN 1 are standard. Drilling patterns DIN 2 are optional.

Dim in.	Actuator size											
	0025	0040	0065	0100	0150	0200	0350	0600	0950	1600	2500	4000
DIN 1	F05	F05	F05	F07	F07	F10	F10	F12	F14	F16	F16	F25
D1	50	50	50	70	70	102	102	125	140	165	165	254
D2	M6x10	M6x10	M6x10	M8x13	M8x13	M10x15	M10x15	M12x18	M16x25	M20x20	M20x20	M16x25
D3	35	35	35	55	55	70	70	85	100	130	130	200
D4	29	32	32	40	50	54	54	68	75	95	95	120
DIN 2	F03	F07	F07	F05	F10	F07	F07	F10	F10	F25*	F25*	F16
D1'	36	70	70	50	102	70	70	102	102	-/-	-/-	165
D2'	M5x8	M8x13	M8x13	M6x10	M10x15	M8x13	M8x13	M10x15	M10x15	-/-	-/-	M20x20
D3'	-	40	40	32	54	50	50	-/-	-/-	-/-	-/-	-/-
D4'	-	55	55	35	70	55	55	-/-	-/-	-/-	-/-	-/-
D9	50	68	68	66	97	94	94	118	135	280	280	273
D10	48	65	65	63	92	90	94	113	130	132	132	269
E1 Max	11.08	14.08	14.08	17.08	17.08	22.10	22.10	27.11	36.16	46.16	46.16	55.24
E1 Min	11.00	14.00	14.00	17.00	17.00	22.00	22.00	27.00	36.00	46.00	46.00	55.00
E2	14	18	18	25	26	28	36	36	58.2	60.2	60.2	72.2
E3	15	15	15	18	28	28	28	28	48.5	59.5	59.5	61.5
E4	34	34	34	34	50	50	50	50	65.5	81.5	81.5	76.75
E5	14	18	21	24	29	32	32	37	48	60	60	73
E6	25	35	35	38	57	57	57	68	86	104	125	133
E7	1	1	1	1	1	1	1	1	1	1	1	1
E8	5	5	5	5	5	5	5	5	6	7	7	2.5

Dimensions - Imperial (ISO5211)

Envelope Dimensions - Solenoid and Top Mounting Interface Sizes 25 - 600

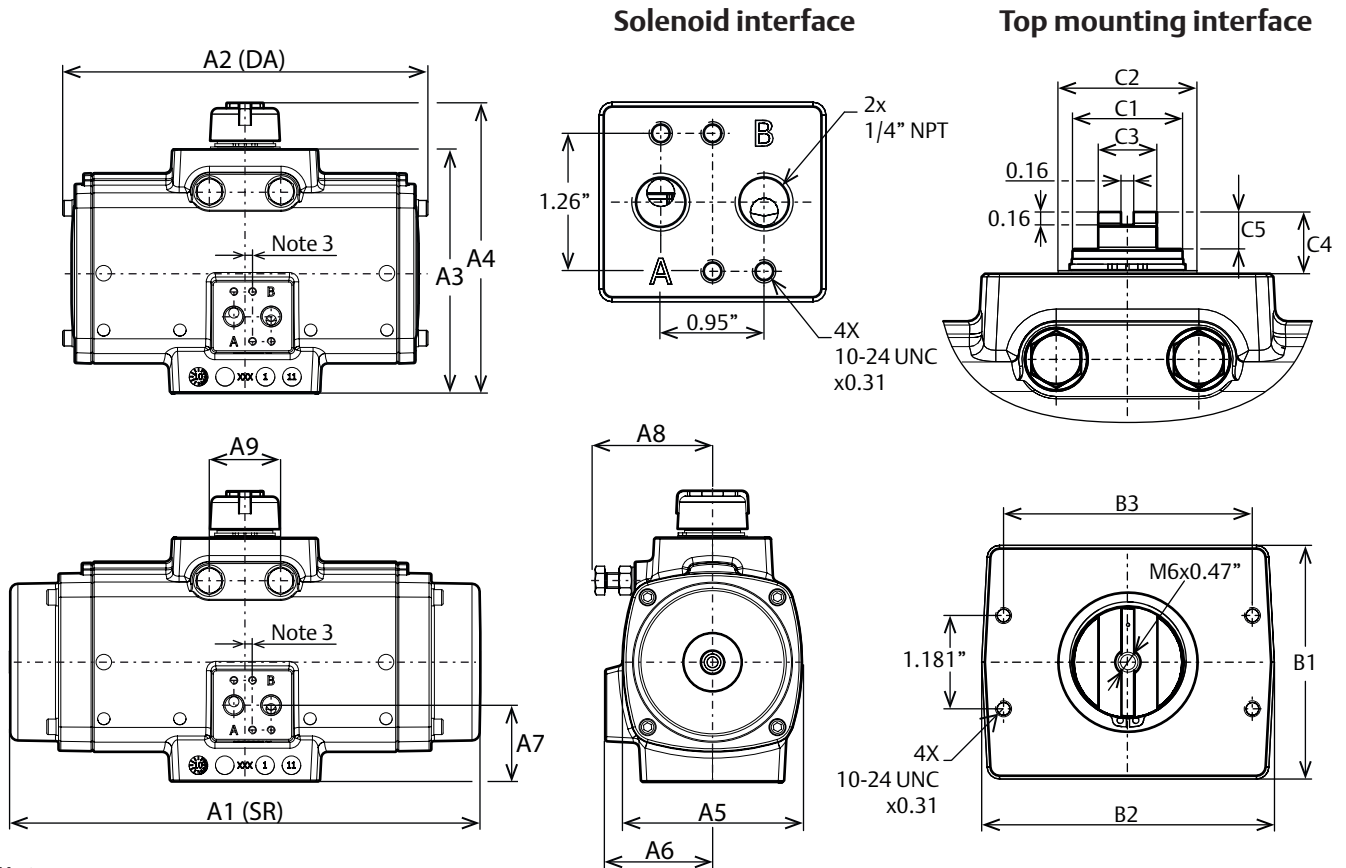

Notes:

1. DA = Double-Acting, SR = Spring-Return
2. Solenoid interface and top mounting interface according to VDI/VDE3845 (NAMUR)
3. The solenoid drilling pattern is shifted 0.16" for size 0025 and 0.08 mm for size 0040 vs the centerline of the actuator.
4. Imperial threads are UNC for fastener thread holes and NPT for air connection ports.

Dim in.	Actuator size							
	0025	0040	0065	0100	0150	0200	0350	0600
A1	6.54	7.55	8.53	9.72	11.97	14.23	15.15	18.73
A2	6.54	7.55	8.53	9.72	9.25	10.43	11.18	14.02
A3	3.59	4.39	4.86	5.14	6.19	6.42	7.92	9.77
A4	4.69	5.47	5.94	6.22	7.28	7.52	9.06	11.50
A5	2.68	3.23	3.62	4.06	4.57	4.88	6.34	7.68
A6	1.91	2.15	2.28	2.50	2.72	2.83	3.35	4.02
A7	1.16	1.34	1.48	1.50	1.93	1.92	1.65	2.64
A8	1.89	2.28	2.72	2.72	2.95	3.43	4.29	5.20
A9	0.71	0.98	1.06	1.10	1.81	1.81	1.81	2.36
B1	1.69	1.77	1.97	2.36	2.95	2.95	3.35	3.86
B2	3.70	3.70	3.70	3.82	3.70	3.70	3.94	5.83
B3	3.15	3.15	3.15	3.15	3.15	3.15	3.15	5.12
C1	0.63	0.87	0.87	0.87	1.34	1.42	1.42	2.17
C2	0.91	1.18	1.18	1.38	1.77	1.77	1.77	2.56
C3	0.55	0.55	0.55	0.55	0.75	0.75	0.75	1.42
C4	0.79	0.79	0.79	0.79	0.79	0.79	0.79	1.18
C5	0.47	0.47	0.47	0.47	0.47	0.47	0.47	0.39

Dimensions - Imperial (ISO5211)

Envelope Dimensions - Solenoid and Top Mounting Interface Sizes 950 - 4000

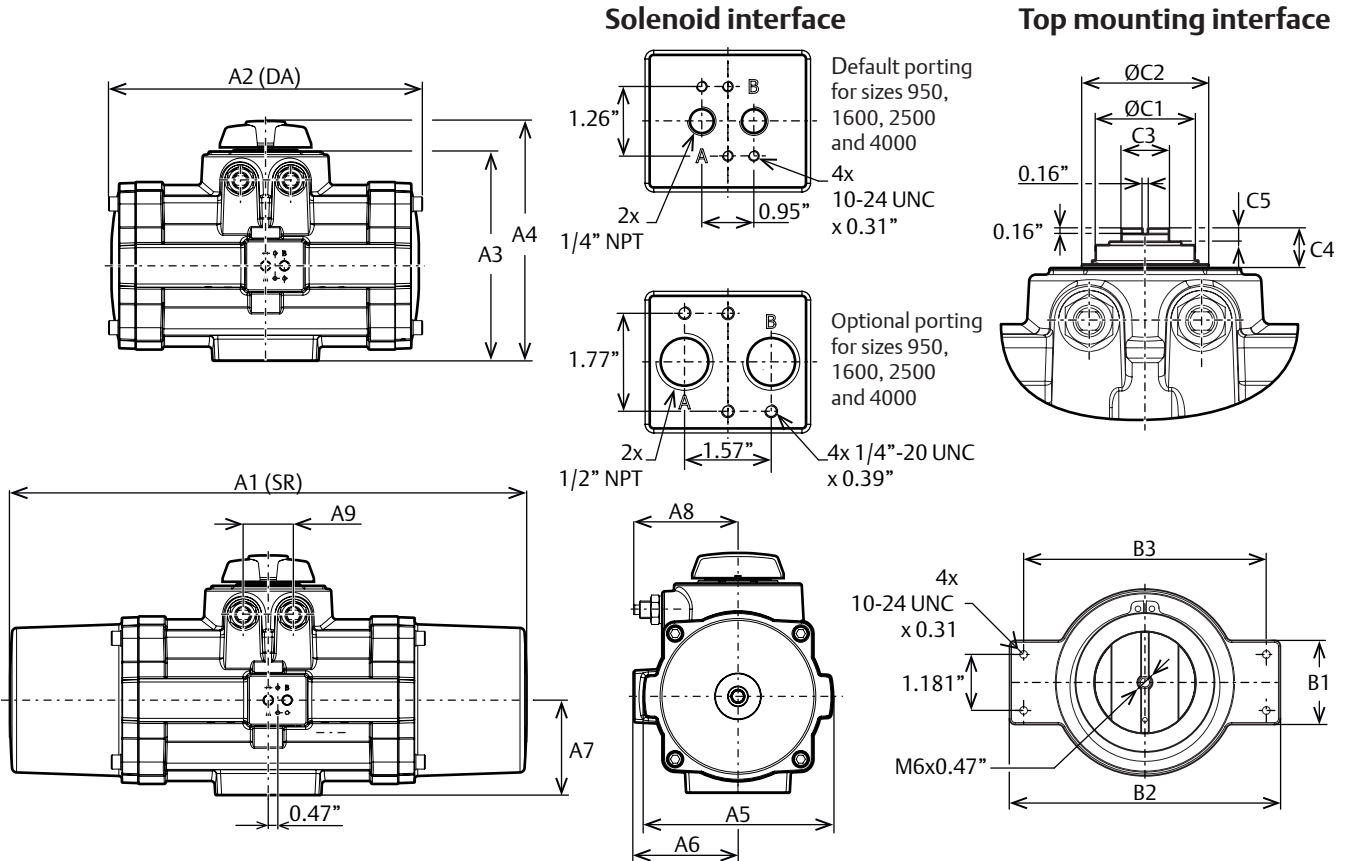

Notes:

1. DA = Double-Acting, SR = Spring-Return
2. Solenoid interface and top mounting interface according to VDI/VDE3845 (NAMUR)
3. The solenoid drilling pattern is shifted 0.95" for sizes 0950 to 4000 vs the centerline of the actuator.
4. The numbers in brackets are for actuators with 1/2" ports.
5. Imperial threads are UNC for fastener thread holes and NPT for air connection ports.

Dim in.	Actuator size			
	0950	1600	2500	4000
A1	25.91	28.82	34.53	37.76
A2	15.75	18.19	21.65	25.55
A3	10.55	11.89	13.94	15.31
A4	12.01	13.35	15.43	16.81
A5	9.41	12.05	13.78	15.75
A6	5.16	5.87	6.69	7.72
A7	4.76	5.39 (5.51) ⁴	6.18 (6.29) ⁴	7.24 (7.32) ⁴
A8	5.16	6.14	7.13	6.89
A9	2.52	3.35	4.02	7.24
B1	1.77	1.77	1.77	1.77
B2	5.71	5.71	5.71	5.71
B3	5.12	5.12	5.12	5.12
C1	2.56	2.95	3.74	3.78
C2	3.27	3.78	4.53	4.53
C3	1.42	1.42	1.42	1.42
C4	1.18	1.18	1.18	1.18
C5	0.39	0.39	0.39	0.39

Dimensions - Imperial (ISO5211)

Valve Flange and Drive Details Sizes 25 - 4000

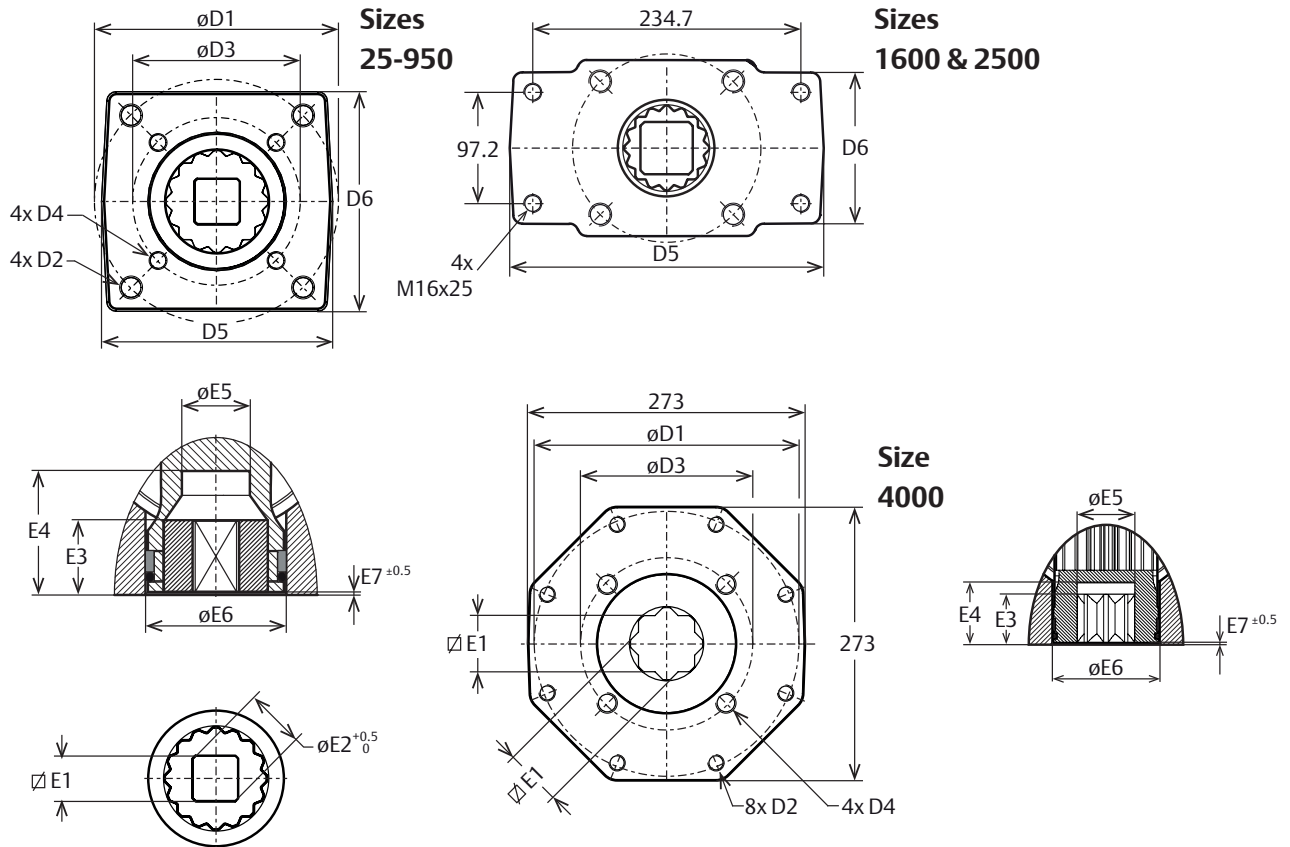

Notes:

1. Flange and square drive according to ISO 5211
2. F25* = For sizes 1600 and 2500 drilling pattern 9.240" x 3.827" represent 4 holes of a F25 drilling pattern.
3. Size 4000 has 2x inner square E1 in the pinion bottom instead of inserts.
4. Imperial threads are UNC for fastener thread holes and NPT for air connection ports.

Dim in.	Actuator size												
	Inches	0025	0040	0065	0100	0150	0200	0350	0600	0950	1600	2500	4000
ISO 1	F05	F07	F07	F07	F07	F10	F10	F10	F12	F14	F16	F16	F25
D1	1.969	2.756	2.756	2.756	4.016	4.016	4.016	4.921	5.512	6.496	6.496	10.000	
D2	1/4"-20 x0.35	5/16"-18 x0.47	5/16"-18 x0.47	5/16"-18 x0.47	3/8"-16 x0.59	3/8"-16 x0.59	3/8"-16 x0.59	1/2"-13 x0.71	5/8"-11 x0.94	3/4"-10 x1.18	3/4"-10 x1.18	5/8"-11 x0.94	
ISO 2	F03	F05	F05	F05	F07	F07	F07	F10	F10	F25*	F25*	F16	
D3	1.417	1.969	1.969	1.969	2.756	2.756	2.756	4.016	4.016	-/-	-/-	6.496	
D4	10-24 x0.31	1/4"-20 x0.35	1/4"-20 x0.35	1/4"-20 x0.35	5/16"-18 x0.47	5/16"-18 x0.47	5/16"-18 x0.47	3/8"-16 x0.59	3/8"-16 x0.59	5/8"-11 x0.94	5/8"-11 x0.94	3/4"-10 x1.18	
D5	1.97	2.68	2.68	2.62	3.82	3.7	3.7	4.65	5.31	11.02	11.02	10.75	
D6	1.89	2.56	2.56	2.48	3.62	3.54	3.7	4.45	5.12	5.2	5.2	10.59	
E1 Max.	0.436	0.554	0.554	0.751	0.751	0.87	1.067	1.067	1.424	1.817	1.817	2.175	
E1 Min.	0.433	0.551	0.551	0.748	0.748	0.866	1.063	1.063	1.417	1.811	1.811	2.165	
E2	0.555	0.713	0.713	0.992	1.004	1.11	1.425	1.425	2.291	2.37	2.37	2.843	
E3	0.591	0.591	0.591	0.709	1.083	1.083	1.083	1.083	1.909	2.343	2.343	2.421	
E4	1.34	1.34	1.34	1.34	1.97	1.97	1.97	1.97	2.58	3.21	3.21	3.02	
E5	0.56	0.71	0.83	0.93	1.12	1.26	1.26	1.44	1.89	2.36	2.36	2.87	
E6	0.96	1.36	1.36	1.5	2.22	2.22	2.22	2.66	3.39	4.09	4.92	5.24	
E7	0.02	0.04	0.04	0.04	0.05	0.05	0.05	0.05	0.04	0.04	0.04	0.04	

Drive Inserts

Key features

- Drive inserts allow actuators to be directly mounted to valves
- Eliminates the need for a bracket and coupling type mounting kit.
- The use of drive inserts significantly cuts the cost of the valve/actuator assembly.
- Standard actuators are fitted with square drive inserts
- Special inserts may have oversized or undersized squares, double-D and shaft key way forms.

Description

The Bettis RPE-Series actuators are fitted with drive inserts. These drive inserts allow actuators to be directly mounted onto suitable valves in accordance with ISO 5211 and eliminates the need for a bracket and coupling type mounting kit. The use of direct mounts significantly cuts the cost of the valve/actuator assembly.

Standard actuators are fitted with square drive inserts in accordance with ISO 5211. The ISO 5211 standard covers parallel and diagonal oriented inner squares (as per old DIN 3337 standard).

Additionally, a wide variety of other inserts are also available. Special inserts may have oversized or undersized squares, double-D and shaft key way forms.

Drive inserts can be supplied on factory built actuators or as loose items and are easily replaceable at distributor or end user level.

Where direct mounts are not possible, for instance on valves with exposed gland packing, the use of inserts often simplifies the design of the mounting kit.

- Material: Aluminium alloy
- Finish : Anodized

Notes:

1. Actuator size RPE4000 does not have inserts. This actuator size has two inner squares (diagonally and parallel oriented) directly in the bottom of the pinion.
2. Page 2 and 3 shows an overview of the default insert sizes and the most common square shaped insert sizes. Please contact your local Bettis representative for all available insert sizes.

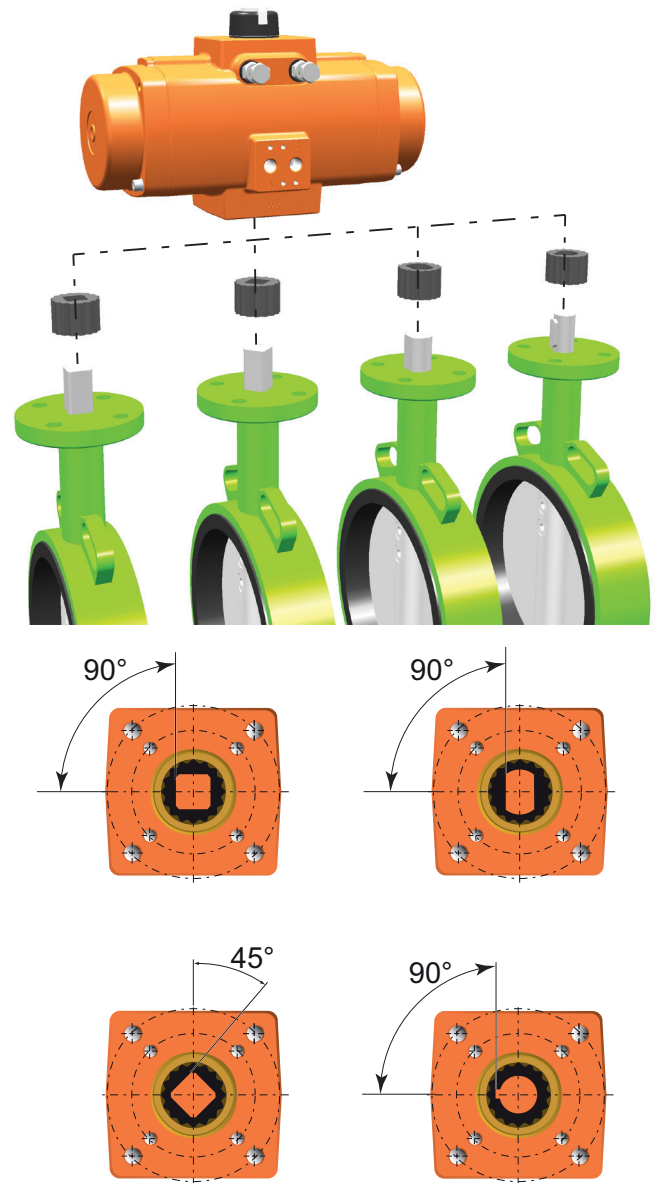

Table 3. Metric drive square overview

Dim. in mm	Inserts with inner-square-dimensions per actuator type										
	0025	0040/ 0065	0100	0150	0200	0350	0600	0950	1600	2500	4000
Standard square drive dimensions											
Type	Insert	Insert	Insert	Insert	Insert	Insert	Insert	Insert	Insert	Insert	Star drive
Parallel ■	11	14	19	19	22	27	27	36	46	46	55
Diagonal ◆	11	14	17	17	22	22	27	36	46	46	55
Optional square insert dimensions (Notes 1)											
	8	8	9	9	9	9	9	14	22	22	No insert
	9	9	10	10	10	10	10	19	27	27	
	10	10	11	11	11	11	11	22	30	30	
		11	12	12	12	12	12	27	36	36	
		12	14	14	14	14	14	30			
		16	16	16	16	16	16				
				22	17	17	17				
				24	19	19	19				
				25	24	24	22				
				27	25	25	24				
					27		25				
Maximum adaptor/valve stem dimensions											
M1	34.5	34.5	34.5	50	50	50	52	64.5	81	81	No insert
M2	-	-	27.5	-	37	37	-	-	-	-	
P1	14.1	18.1/ 21.2	23.5	28.5	32.2	32.2	36.8	48.3	60.2	60.2	
P2	-	-	25.2	-	36.3	36.3	-	-	-	-	
Sq. max.	11	16	19	27	27	27	27	36	46	46	
D max.	13.8	21	23.6	33.6	33.6	33.6	33.6	45	60	60	

1. Above table shows an overview of the default insert sizes and the most common square shaped insert sizes. Please contact your local Bettis representative for all available insert sizes.

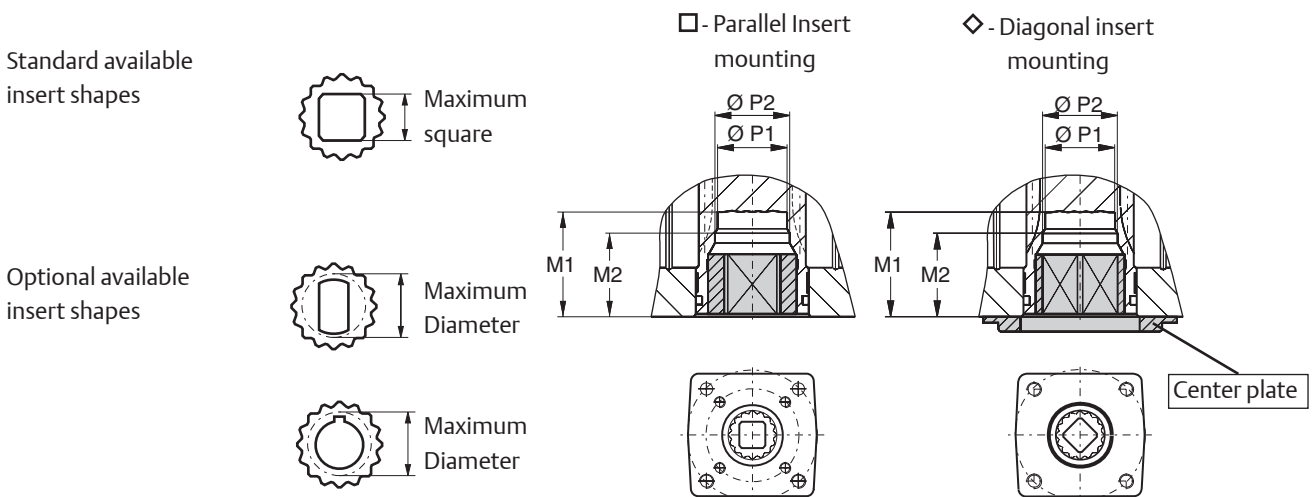
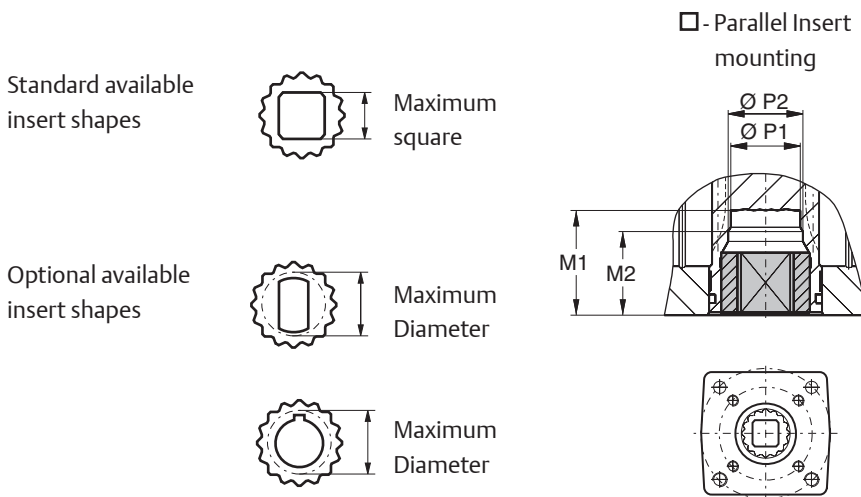

Table 4. Imperial drive square overview

Dim. in inches	25	0040/ 0065	100	150	200	350	600	950	1600	2500	4000
Standard square drive dimensions											
Type	Insert	Insert	Insert	Insert	Insert	Insert	Insert	Insert	Insert	Insert	Star drive
Parallel ■	0.433	0.551	0.748	0.748	0.866	1.063	1.063	1.417	1.811	1.811	2.165
Diagonal ◆	0.433	0.551	0.669	0.669	0.866	0.866	1.063	1.417	1.811	1.811	2.165
Optional square insert dimensions (Notes 1)											
	0.315	0.315	0.354	0.354	0.354	0.354	0.354	0.551	0.866	0.866	No insert
	0.354	0.354	0.394	0.394	0.394	0.394	0.394	0.748	1.063	1.063	
	0.394	0.394	0.433	0.433	0.433	0.433	0.433	0.866	1.181	1.181	
		0.433	0.472	0.472	0.472	0.472	0.472	1.063	1.417	1.417	
		0.472	0.551	0.551	0.551	0.551	0.551	1.181			
		0.630	0.630	0.630	0.630	0.630	0.630				
				0.866	0.669	0.669	0.669				
				0.945	0.748	0.748	0.748				
				0.984	0.945	0.945	0.866				
				1.063	0.984	0.984	0.945				
					1.063		0.984				
Maximum adaptor/valve stem dimensions											
M1	1.358	1.358	1.358	1.969	1.969	1.969	2.047	2.539	3.189	3.189	No insert
M2	-	-	27.5	-	37	37	-	-	-	-	
P1	0.555	0.717/ 0.835	0.925	1.122	1.268	1.268	1.449	1.902	2.37	2.37	
P2	-	-	0.992	-	1.429	1.429	-	-	-	-	
Sq. max.	0.433	0.630	0.748	1.063	1.063	1.063	1.063	1.417	1.811	1.811	
D max.	0.543	0.827	0.929	1.323	1.323	1.323	1.323	1.772	2.362	2.362	

1. Above table shows an overview of the default insert sizes and the most common square shaped insert sizes. Please contact your local Bettis representative for all available insert sizes



Insert Removal tool

Description

The standard Bettis RPE-Series actuators are equipped with Square-Drive inserts according to ISO5211. When assembled at the factory, the inserts are press-fitted on an edge in the pinion bottom. In order to be able to replace these standard inserts, these insert removal tools will help you to easily remove the standard insert from the pinion bottom.

Availability

The insert removal tools are available in two versions and can be used up to actuator size 600. For larger actuator sizes, up to size 2500, it is recommended to use a generic pulley puller.

Intended use:

These insert removal tools are intended to be used just before the installation of the actuator onto a valve and where the default insert needs to be replaced by an insert with a different size or shape.

Operation:

The insert removal tools are equipped with 3 square bits that fit exactly in the insert square of the actuator. Make sure the square bits are as high as possible on the threaded rod. Then you can insert (1) and rotated 45° (2) the tool and one of the square bits will hook under the insert.

The knob (3) on the tool can now be rotated until the insert gets loose (4) and it can be removed from the pinion's bottom.

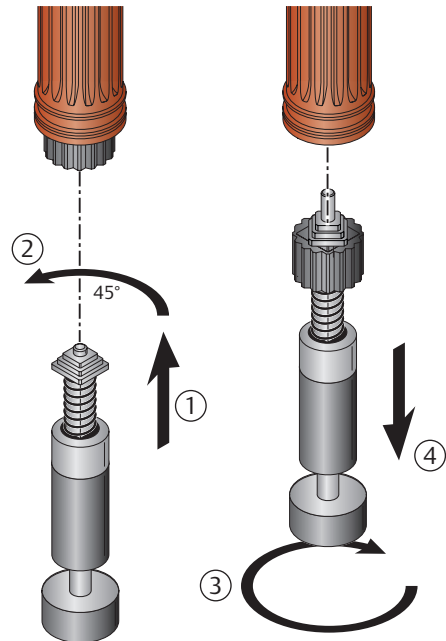

Specifications:

Tool part nr.:	Squares:	Actuator sizes:
VA590.00.001	11, 14 and 17	25, 40, 65, 100, 150
VA590.00.002	19, 22 and 27	100, 150 200, 350, 600

Materials:

Body, Knob and bits: Carbon steel, Zinc Plated

Center Plate / Center ring

Key features

- Durable design allows good alignment of actuator and valve.
- Prevents wear on valve spindle or mounting kit due to misalignment.
- Center plates can easily be added to standard actuator.
- Most actuators are available with two center plates for flexible valve mounting.
- Equipped with slot to release pressure, trapped between valve and actuator.

Description:

Bettis RPE Series actuators can be equipped with a center plate which takes care that actuator and valve (or valve mounting kit) are aligned when mounted. For most of the actuator sizes two centering plates are available. Size 4000 is available with a stainless steel center ring in a machined groove in the valve flange.

Specifications:

- Material plate: Nylon PA6, Black
- Material ring: Stainless Steel (Size 4000 only)

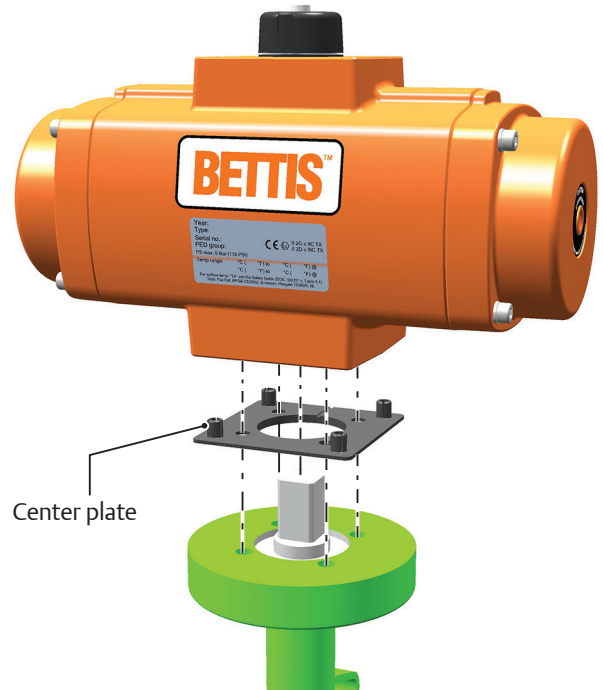

Bettis RPE Series actuator models ⁽¹⁾

	0025	0040	0065	0100	0150	0200	0350	0600	0950	1600	2500	4000 ⁽²⁾
Default ⁽¹⁾	F05	F05	F05	F07	F07	F10	F10	F12	F14	F16	F16	F25
Option	-/-	F07	F07	F05	F10	F07	F07	F10	-/-	-/-	-/-	-/-

Notes:

1. Default selection if actuator needs to comply to DIN 3337, see dimension sheet BED.04.01.EN.
2. Size 4000 is available with a stainless steel center ring in a machined groove in the valve flange.

Visual indicator Bettis RPE-Series actuators

Description

Bettis RPE-Series actuators have a large visual position indicator which allows clear indication of the valve's position at almost any position.

Bettis RPE-Series indicator is designed for position indication of actuators mounted "in line" with the pipe line and mounted "cross line" with the pipe line.

Conversion is easily done by turning the indicator 90° and reassemble back in place.

By default, the position indicator will be mounted "in line".

Specifications:

Materials:

- Indicator knob: ABS, Black
- Indicator arrow: ABS, White
- Indicator screw: SS Head cap screw M6x12

Center piece of large indicator.

The large indicator, for sizes 600-4000, is designed with a press fitting onto the pinion top. This way, the indicator will stay also on the pinion top without the indicator screw fitted. This press fitting feature together with the option to punch out the center piece of the vane of the large indicator, offers a passageway for a switch box or positioner shaft, up to a diameter of 20mm (0.787").

Ø 20mm (0.787")



Punched out center piece



Indicator mounting "In-line"

Size 12 - 350

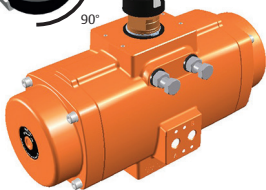
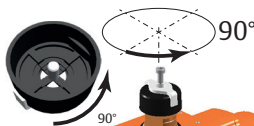
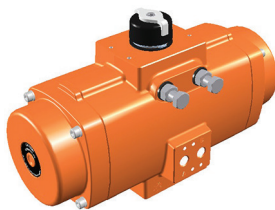

Size 600 - 4000

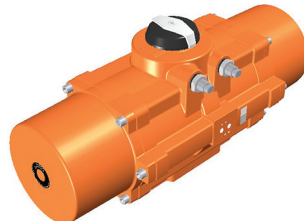

90°

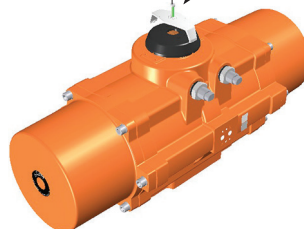

Indicator mounting "Across Line"

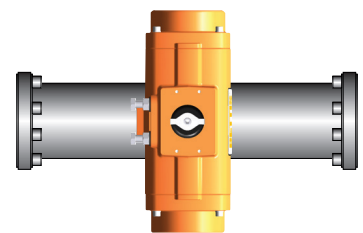
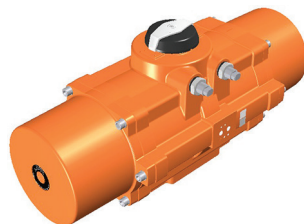
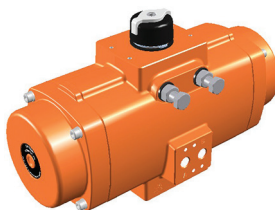

High Temperature Execution

Description

A double piston, rack and pinion pneumatic actuator, incorporating an anti-blowout pinion and a piston support system with high duty synthetic bearings at all bearing points.

This version is a standard aluminum actuator, but incorporating grease, O-ring seal and bearing materials, suitable for high temperature operation up to 250°F (120°C).

Specification

Max. pressure: 120 psig (8 barg)
 Torque: Standard
 Media: Air or non corrosive gas
 Temperature: 14°F to +250°F (-10°C to +120°C)
 Finish: Polyurethane powder coating
 (see data sheet BRG.01.03.EN)

Spare parts

Dedicated high temperature spare part kits are available for maintenance or to convert a standard actuator in to a version suitable for high temperature operation.

High temperature components:
 - Castrol High temperature grease
 - Viton (FPM) O-ring seals
 - PTFE 25% carbon filled piston bearings
 - Nylon 66 resin containing Aramid Fibre & PTFE for bearing strip piston rack and pinion bearings.

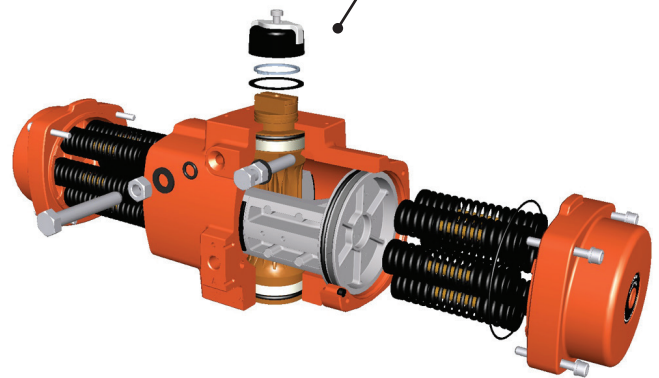

Description	Material
House	Cast Aluminium alloy
End cap	Cast Aluminium alloy
Piston	Cast Aluminium alloy
Pinion	High grade aluminium
Spring cartridge	Spring steel
Bearing strip piston rack	Nylon 66 resin containing Aramid Fibre & PTFE
Bearing piston	PTFE 25% carbon filled
Bearing pinion	Nylon 66 resin containing Aramid Fibre & PTFE
Thrust washer	POM, black UV stabilized
End cap screw	Stainless Steel
Circlip	Spring steel
O-ring seal pinion	Viton FPM
O-ring seal piston	Viton FPM
O-ring seal end cap	Viton FPM
O-ring seal limit stop	Viton FPM
B-port seal	Silicon rubber
Limit stop screw	Stainless steel
Limit stop nut	Stainless steel
Limit stop washer	PA66
Warning sticker	Polyester
Indicator assembly	ABS + stainless steel screw
Center plate (option)	Nylon PA6, Black
Insert drive	Aluminium alloy
Grease	Castrol High temperature grease

Low Temperature Execution

Description

A double piston, rack and pinion pneumatic actuator, incorporating an anti-blowout pinion and a piston support system with high duty synthetic bearings at all bearing points.

This version is a standard aluminum actuator, but incorporating grease and O-ring seal materials, suitable for low temperature operation down to -40°F (-40°C).

Notes:

When operating actuators in sub-zero temperatures (< 0°C or < 32°F) care should be taken to counter the effects of freezing condensate inside the actuator.

Specification

Max. pressure:	120 psig (8 barg)
Torque:	Standard
Media:	Air or non corrosive gas
Temperature:	-40°C to +80°C (-40°F to +176°F)
Finish:	Polyurethane powder coating (see data sheet BRG.01.03.EN)
Cycle life:	Replace the seals after 250.000 cycles

Spare parts

Dedicated low temperature spare part kits are available for maintenance or to convert a standard actuator in to a version suitable for low temperature operation.

Low temperature components:
- Castrol Tribol GR TT 1 PD grease
- Silicone (MVQ70 rubber) O-ring seals

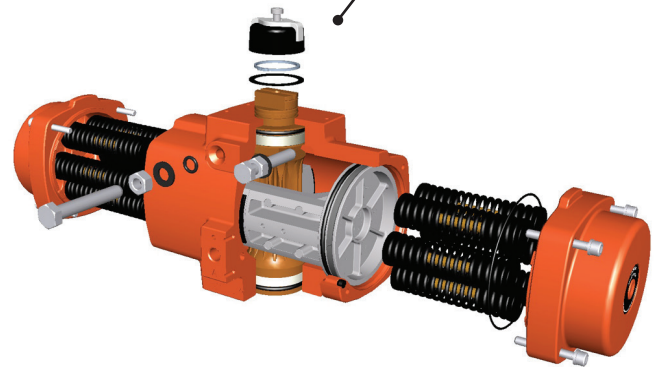

Description	Material
House	Cast Aluminium alloy
End cap	Cast Aluminium alloy
Piston	Cast Aluminium alloy
Pinion	High grade aluminium
Spring cartridge	Spring steel
Bearing strip piston rack	POM
Bearing piston	PTFE 25% carbon filled
Bearing pinion	POM
Thrust washer	POM, black UV stabilized
End cap screw	Stainless Steel
Circlip	Spring steel
O-ring seal pinion	Silicone MVQ70
O-ring seal piston	Silicone MVQ70
O-ring seal end cap	Silicone MVQ70
O-ring seal limit stop	Silicone MVQ70
B-port seal	Silicon rubber
Limit stop screw	Stainless steel
Limit stop nut	Stainless steel
Limit stop washer	PA66
Warning sticker	Polyester
Indicator assembly	ABS + stainless steel screw
Center plate (option)	Nylon PA6, Black
Insert drive	Aluminium alloy
Grease	Castrol Tribol GR TT 1 PD grease

Bettis RPE-Series with Stainless Steel pinion

AISI 316 Stainless Steel Pinion + Fasteners (A4-70)

Key features

- Extended corrosion resistant properties for applications where the standard pinion material is not sufficient.
- AISI 316 grade stainless steel pinion material.
- A4-70 grade stainless steel fasteners.
- Available with parallel and diagonal square drive for ISO5211 or DIN3337 valve mounting.
- Typically suitable for areas where standard aluminum pinions fail prematurely due to heavy corrosion, for instance protected areas on off-shore platforms.

Coating:

Polyurethane powder coating for exterior use (= default coating).

Pinion:

Stainless steel
AISI 316

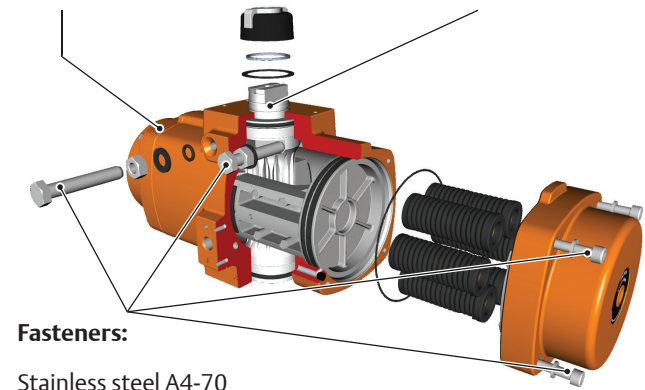

Fasteners:

Stainless steel A4-70

Description

Bettis RPE-Series with AISI 316 stainless steel pinion and fasteners (A4-70) offers an extended corrosion resistance in environments where standard actuators with aluminium pinions might fail prematurely due to higher corrosion levels.

AISI 316 grade stainless steel pinion material

Stainless steel 316 has excellent corrosion resistance when exposed to a range of corrosive environments and media. It is usually regarded as “marine grade” stainless steel.

A4-70 Grade stainless steel fastener material

A4 Grade fasteners are made of AISI 316 stainless steel and comes with the same excellent corrosion resistance as the pinion material.

As such actuators with AISI 316 stainless steel pinions and fasteners can be used in very corrosive environments like near sea shore plants or protected areas on off-shore platforms.

Technical data:

Coating:	Polyurethane powder coating for exterior use (= default coating).
Color:	Bettis Orange (RAL 2009)
Corrosion resistance:	1000hr, ASTM B117
Max. Temperature:	-20° to + 80°C (-4°F to +176°F)
Materials Housing:	Aluminum alloy, anodized
Pinion:	Stainless Steel AISI 316
Fasteners:	Stainless steel A4-70
Type Sticker:	Polyester
Application:	Optional on Bettis RPE-Series actuators.
Dimensions:	See page 2

Availability:

- When ordering the optional AISI 316 stainless steel pinion, the actuator will also be equipped with the Stainless steel A4-70 grade fasteners.
- The optional A4-70 grade stainless steel fasteners can also be ordered as an individual upgrade feature on default actuators.
- For actuator model string definition of these options see data sheet BEG.02.01.EN

Dimension for Bettis RPE-Series actuators with Stainless Steel pinions.

Bettis RPE-Series actuators with the stainless steel pinions are not suitable for the use of drive inserts. The pinions of these actuators are fitted with 2 drive squares (rotated at 45°) in the pinion bottom. These drive squares are according ISO5211. All the other actuator dimensions are the same. Please refer to:

- BEM.04.01.EN for Metric ISO units
- BED.04.01.EN for Metric DIN units (with center plate)
- BEI.04.01.EN for Imperial ISO units

For the drive square dimensions of the stainless steel pinions, see below drawing and table.

Dim. in mm	Drive square dimensions Stainless Steel pinions											
	25	40	65	100	150	200	350	600	950	1600	2500	4000
S1 Max.	11.08	14.08	14.08	19.13	22.11	22.11	27.11	27.11	36.16	46.16	46.16	55.19
S1 Min.	11.00	14.00	14.00	19.00	22.00	22.00	27.00	27.00	36.00	46.00	46.00	55.00
S2^{+0.5 0}	14.4	18.5	18.5	22.5	22.5	28.5	36.5	36.5	48.2	60.2	60.2	72.2
S3	17	17	17	20	28	28	30	31	40.5	53.5	53.5	61.5
S4	27	27	27	27	40	40	38	38	50.5	65.5	65.5	76.5
S5	15	19	19	23	23	29	37	37	48.8	60.8	60.8	72.8

Dim. in inch	Drive square dimensions Stainless Steel pinions											
	25	40	65	100	150	200	350	600	950	1600	2500	4000
S1 Max.	0.436	0.554	0.554	0.753	0.870	0.870	1.067	1.067	1.424	1.817	1.817	2.173
S1 Min.	0.433	0.551	0.551	0.748	0.866	0.866	1.063	1.063	1.417	1.811	1.811	2.165
S2^{+0.02 0}	0.57	0.73	0.73	0.89	0.89	1.12	1.44	1.44	1.90	2.37	2.37	2.84
S3	0.67	0.67	0.67	0.79	1.1	1.1	1.18	1.22	1.59	2.11	2.11	2.42
S4	1.06	1.06	1.06	1.06	1.57	1.57	1.50	1.50	1.99	2.58	2.58	3.01
S5	0.59	0.75	0.75	0.91	0.91	1.14	1.46	1.46	1.92	2.39	2.39	2.87

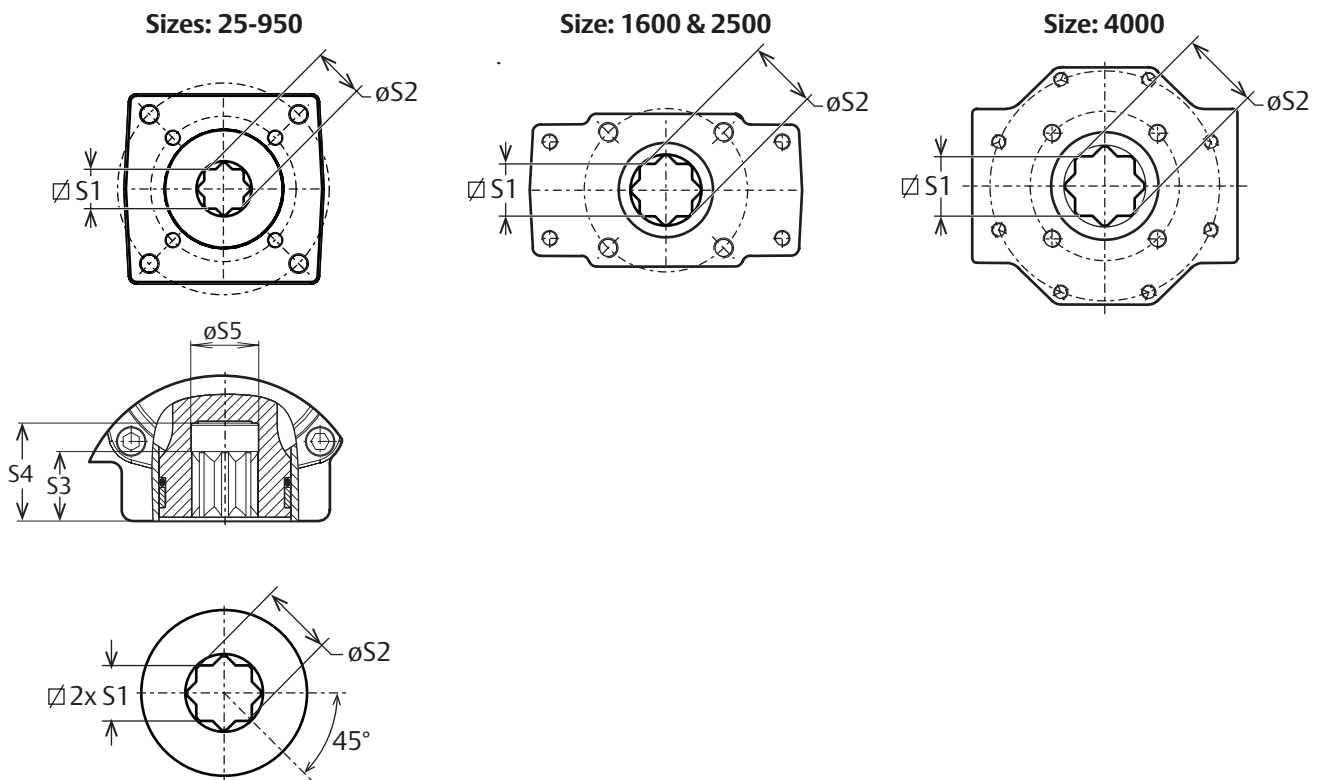

Fast Cycling RPE-Series actuators

Increase the cycle speed of actuators

Cycle speed:

In general pneumatic Bettis RPE-Series actuators are equipped with large internal air porting that allows adequate cycling under normal circumstances and when using generic solenoid valves to operate the actuator, the achieved cycle speed is normally sufficient.

In order to increase the cycle speed of the Bettis RPE-Series two options are available:

- High Flow plates
- Actuators with 1/2" air connection porting (only available for sizes RPE 950 to RPE 4000)

High Flow plates on Standard actuators

If faster cycle times are required (<0.5 or <1 second), 1/4" solenoid valves or pneumatic fitting material can become a problem. These components will then function as a throttle, reducing the potential maximum air flow and as such the limiting the maximum cycle speed.

In order to use the maximum cycle speed potential of a standard actuator, the 1/2" High Flow adaptor plate allows the fitting of larger solenoid valves and pneumatic fitting material and as such the increase the maximum cycle speed.

Construction:

The High Flow Plate is a aluminum plate which can be mounted directly to solenoid interface on actuators which are designed according VDI/VDE 3845 (NAMUR). The plate is supplied with fasteners and seals.

The customer side of the plate is equipped with one larger 1/2" NPT or BSP air connection (A-port) for piped solenoid control.

Materials:

- Block: Aluminium alloy, black anodized (10-15µm)
- Fasteners: Stainless steel
- O-ring seals: NBR Rubber

Table 1. High Flow plates

Part nr:	Execution:
VA306.00.310	1/2" NPT
VA306.00.320	1/2" BSP

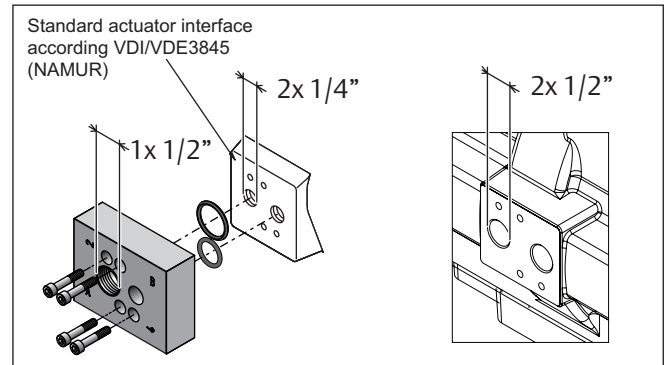

Actuators with 1/2" air connection porting.

In order to increase the cycle speed of actuator of the larger sizes RPE950 to RPE4000, these actuators are available with 1/2" BSP or NPT air connections for both the A and B port and comply with the 1/2" pneumatic connection specification of EN15714-3.

Additionally the internal air channels of the housing are larger than on the standard housing. Together with the mounting of 1/2" solenoid and or quick exhaust this allows very fast cycle speeds.

Maximum cycle speed

In order to select the correct actuator configuration, please find below a table of maximum cycle speeds that can be achieved for the standard 1/4" ported houses and the optional 1/2" ported houses.

1. For practical considerations follow the next recommendations.
2. Consult the nearest Bettis representative or Emerson office for technical support.

Table 2. Maximum cycle speeds (seconds)

Actuator size	House with 1/4" ports	House with 1/2" ports
12	0.4	Not available
25	0.4	Not available
40	0.5	Not available
65	0.6	Not available
100	0.7	Not available
150	0.8	Not available
200	1.0	Not available
350	1.5	Not available
600	2.2	Not available
950	2.5	0.8
1600	3.3	1.2
2500	5.4	1.7
4000	10.7	3.2

Test conditions:

Solenoid with flow capacity:

- Up to size 600	0.6 m ³ /hr	Not available
- 950 and larger	1.45 m ³ /hr	2.49 m ³ /hr

Pipe diameter:

- Up to size 600	6 mm	Not available
- 950 and larger	10 mm	12 mm

Medium: Clean air

Supply pressure: 5.5 bar/80psi

Load: With average load

Stroke: 90°

Temperature: Room temperature

Notes:

Faster stroking speeds are available but may require special design. If faster stroking speeds are required contact the engineering department.

Recommendations:

- The High Flow Plate or the 1/2" ported housing on its own do not make the cycle time of an actuator faster. Take care that there is sufficient air supply capacity at actuator:
 - Air supply capacity must be larger than the Cv or Kv value of the control solenoid valve.
 - Use tubing with sufficient large diameter.
 - Make tubing from the main air supply to the actuator as short as possible.
- Consider the use of Quick Exhaust valves in combination with High Flow Plate or the 1/2" ported housing.
- In general the actuators life cycle is reduced when cycling very fast.

Table 3. Port dimension options RPE950 to RPE4000

Dim	Metric Units		Imperial Units	
	1/4"	1/2"	1/4"	1/2"
S	1/4" BSP	1/2" BSP	1/4" NPT	1/2" NPT
S1	32	45	1.26"	1.77"
S2	24	40	0.94"	1.57"
S3	M5x8	M6x10	UNC 10-24 x 0.31"	1/4"UNC x 0.39"

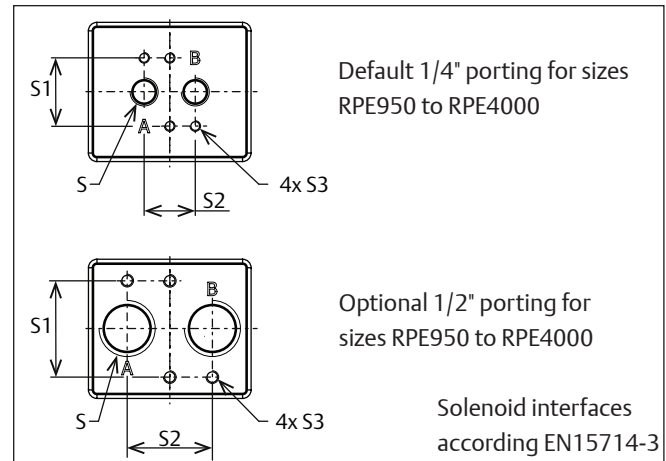
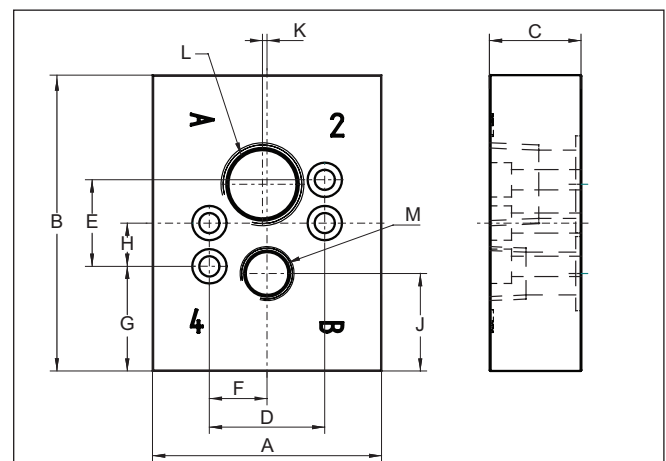

Table 4. High Flow Plate Dimensions:

Dimension in:	mm	Inch
A	63.5	2.50
B	82	3.23
C	25.4	1.00
D	32	1.26
E	25	0.98
F	16	0.63
G	29	1.14
H	12	0.47
J	27	1.06
K	1.27	0.05
L	1/2" BSP	1/2" NPT
M	1/4" BSP	1/4" NPT



Actuator Operating Media Specification

For use with natural gas

Description

The standard Bettis RPE-Series actuator can be operated with natural gas. The natural gas should be qualified as "Sweet" and "Dry" (a.k.a. "Pipeline quality").

"Sweet" natural gas:

- Contains < 2 volume % of CO₂
- Contains < 1 volume % of H₂S

If the natural gas contains more than 2 volume % of CO₂ and more than 1 volume % of H₂S it is regarded as Sour Natural Gas and is not suitable as operating medium for the standard RPE-Series actuator.

"Dry" natural gas:

The natural gas should be as dry as possible. The recommended pressure dew point of the natural gas should be at least 10°C less than the lowest ambient temperature expected.

Notes:

1. Care should be taken that fittings, tubing and controlling valves are also compatible to the media.
2. Natural gas is according Pressure Equipment Directive (PED) 2014/68/EU rated as a Group 1 gas (flammable, explosive or poisonous gasses). A limited range of the standard Bettis RPE Series actuator sizes are suitable for PED Group 1 gasses. For use in the European Union special product labeling is required and available.

Bettis RPE-Series

The standard aluminium actuator, is utilizing materials which overcome the problems associated with the use of natural (sweet) gas as an operating media, these are:

1. Sulfide stress cracking of metallic parts
2. The chemical attack by hydrogen sulfide and organic sulphur compounds.
3. No brass or bronze components.

Warning:

- Natural gas is a flammable, explosive and poisonous gas.
- Take appropriate measures to prevent ignition and poisoning during installation, commissioning and operation, according local or national law.

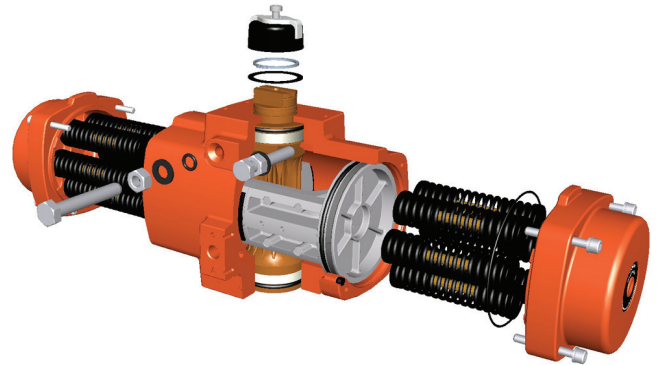

General specifications:

Pressure:	8.3 bar max. (120 psi)
Torque:	Standard, see data sheet(s)
Spring return:	Nm: BEM.03.01.EN Lbf.in: BEI.03.01.EN
Double acting:	Nm: BEG.03.02.EN Lbf.in: BEG.03.02.EN
Dimensions:	See data sheets: Imperial ISO5211 BEI.04.01.EN Metric ISO5211 BEM .04.01.EN Metric DIN3337 BED.04.01.EN
Operating Media:	"Sweet" and "Dry" natural gas (a.k.a. "Pipeline quality")
Dew Point:	At least 10°C less than the lowest ambient temperature expected.
Coating :	Polyurethane powder coating for exterior use.
Salt spray test :	ASTM B117: 1500 hours
Color :	Orange (RAL 2009)
Materials:	Housing: Anodized aluminium alloy Endcaps: Anodized aluminium alloy Pistons: Chromated aluminium alloy Pinion: High grade aluminium alloy, hard anodized.
Fasteners:	Stainless steel or alloy steel with Deltatone® treatment
Type Sticker:	Polyester

World Area Configuration Centers (WACC) offer sales support, service, inventory and commissioning to our global customers.

Choose the WACC or sales office nearest you:

NORTH & SOUTH AMERICA

19200 Northwest Freeway
Houston TX 77065
USA
T +1 281 477 4100

Av. Hollingsworth
325 Iporanga Sorocaba
SP 18087-105
Brazil
T +55 15 3413 8888

ASIA PACIFIC

No. 9 Gul Road
#01-02 Singapore 629361
T +65 6777 8211

No. 1 Lai Yuan Road
Wuqing Development Area
Tianjin 301700
P. R. China
T +86 22 8212 3300

MIDDLE EAST & AFRICA

P. O. Box 17033
Jebel Ali Free Zone
Dubai
T +971 4 811 8100

P. O. Box 10305
Jubail 31961
Saudi Arabia
T +966 3 340 8650

24 Angus Crescent
Longmeadow Business Estate East
P.O. Box 6908 Greenstone
1616 Modderfontein Extension 5
South Africa
T +27 11 451 3700

EUROPE

Holland Fasor 6
Székesfehérvár 8000
Hungary
T +36 22 53 09 50

Strada Biffi 165
29017 Fiorenzuola d'Arda (PC)
Italy
T +39 0523 944 411

For complete list of sales and manufacturing sites, please visit www.emerson.com/actuationtechnologieslocations or contact us at info.actuationtechnologies@emerson.com

www.emerson.com/bettis

©2018 Emerson. All rights reserved.

The Emerson logo is a trademark and service mark of Emerson Electric Co. Bettis™ is a mark of one of the Emerson family of companies. All other marks are property of their respective owners.

The contents of this publication are presented for information purposes only, and while every effort has been made to ensure their accuracy, they are not to be construed as warranties or guarantees, express or implied, regarding the products or services described herein or their use or applicability. All sales are governed by our terms and conditions, which are available on request. We reserve the right to modify or improve the designs or specifications of our products at any time without notice.

BETTIS™

EMERSON™

Product configuration code

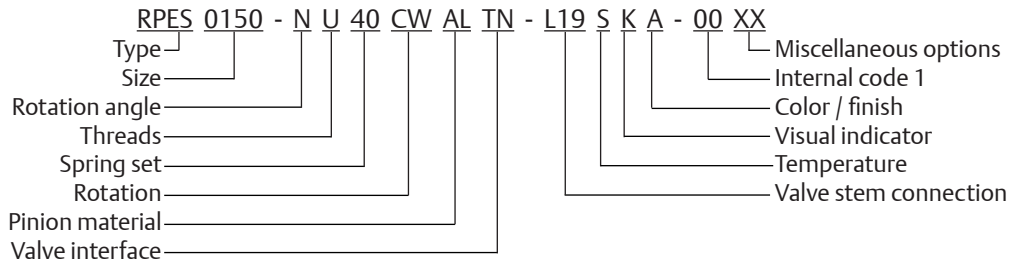

Type			
RPED	Double Acting		
RPES	Spring Return		
Size			
0025	Size 0025	0350	Size 0350
0040	Size 0040	0600	Size 0600
0065	Size 0065	0950	Size 0950
0100	Size 0100	1600	Size 1600
0150	Size 0150	2500	Size 2500
0200	Size 0200	4000	Size 4000
Rotation angle			
N	90° rotation angle		
Threads			
M	Metric ISO 5211		
U	UNC/NPT/Imperial		
Spring Set			
00	Double Acting (no springs)		
10	Spring Set 10	40	Spring Set 40
20	Spring Set 20	50	Spring Set 50
30	Spring Set 30	60	Spring Set 60
Rotation direction			
CW	Spring to Close/Clock Wise		
CC	Spring to Open/Counter Clock Wise		
Pinion Material			
AL	High Grade Aluminium, Hard anodized		
SS	Stainless steel ASI 316 (+ A4-70 SS fasteners)		
Valve Interface ⁽²⁾			
TN	Standard ISO 5211 interface		
SY	Small interface with center plate (DIN3337)		
LY	Large interface with center plate (DIN3337)		

Notes:
See next page.

Valve Stem Connection				
Actuator size	Square	Aluminum		Stainless Steel ⁽⁴⁾
		Parallel drive ■	Diagonal drive ◆	Star drive ⚙
No insert		000		Not applicable
0025	11mm / 0.433"	L11	D11	Q11
0040 & 0065	14mm / 0.551"	L14	D14	Q14
0100	17mm / 0.669"		D17	Q19
0150	17mm / 0.669"	L19		
	19mm / 0.748"		D17	Q22
0200	22mm / 0.866"	L22	D22	Q22
0350	22mm / 0.866"		D22	Q27
	27mm / 1.063"	L27		
600	27mm / 1.063"	L27	D27	Q27
950	36mm / 1.417"	L36	D36	Q36
1600 & 2500	46mm / 1.811"	L46	D46	Q46
4000 ⁽³⁾	55mm / 2.165"	Q55	Q55	Q55
Temperature Range				
S	Standard: -20°C to +80°C (-4°F to +176°F)			
H	High: -10°C to +120°C (+14°F to +250°F)			
L	Low: -40°C to +80°C (-40°F to +176°F)			
Visual Indication Code				
K	Standard (Knob)			
N	No Visual Indication			
Finish				
B	Standard coating (Bettis Orange)			
Internal code 1				
00	Standard			
Miscellaneous options				
XX	Standard			
H1	1/2" High Flow plate			
P1	1/2" Porting according EN 15714-3 (only sizes 25-600)			

Notes:

1. The options, listed here, are all options available. Not all options apply to all configurations.
2. Valve Interface:
 - Option "S"; Small Interface with Center Plate (DIN3337) is not available for sizes 0025, 0950 and 4000.
 - Option "L"; Large Interface with Center Plate (DIN33337) is not available for sizes 1600 and 2500
 - Option "L" for size 4000 is a stainless steel ring, mounted in a groove in the valve flange.
3. Size 4000 does not have inserts but has two inner squares (diagonally and parallel oriented) directly in the bottom of the pinion.
4. Actuators with stainless steel pinions do not have inserts but have two inner squares (diagonally and parallel oriented aka "Star Drive") directly in the bottom of the pinion.
5. Contact your local Bettis representative for additional insert options.
6. PED Group 1 Label only available up to size 950.

General Specifications

Torque Range

- Double-Acting: 220 to 38510 lbf.in (25 to 4338 Nm) at 80psig (5.5 barg)
- Spring-Return: 118 to 15867 lbf.in (5 to 1793 Nm) spring end torque at maximum spring set.

Pressure Range

- Double-Acting:
 - 2.9 to 120 psig (0.2 to 8.3 barg)
- Spring-Return:
 - 87 to 120 psig (6 to 8.3 barg), with maximum spring set
 - 43.5 to 120 psig (3 to 8.3 barg), reduced spring quantity

Pressure Media

- Air, dry or lubricated and inert gases
- Dew point at least 10K below ambient temperature
- For sub-zero applications, take appropriate measures
- Mentioned pressure levels are "gauge pressures". Gauge pressure is equal to absolute pressure minus atmospheric pressure.

Cycle life

- Normal working life is 500,000 cycles according EN15714-3, where 1 cycle is 1 open stroke and 1 close stroke.

Finish

- Body: Anodized and polyurethane powder coated
- End caps: Anodize and polyurethane powder coated
- Pistons: Chromated
- Pinion: Hard Anodized
- Fasteners: Stainless steel or Deltatone® coated

Lubrication

- Castrol High Temperature grease (or equivalent)

Temperature Range

- Standard: -4°F to +176°F (-20°C to +80°C)
- Option:
 - Low temperature: -40°F to +176°F (-40°C to +80°C)
 - High temperature: +14°F to +250°F (-10°C to +120°C)

Angle of Rotation

- Factory set at 90°
- Adjustable range:
 - Size 25 to 600: -5° to +10° and +80° to 95°
 - Size 950 to 4000: -3° to +10° and +80° to 93°

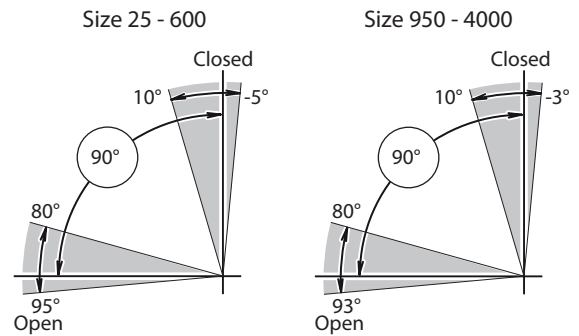

Compliance to International Standards

- Valve flange: ISO 5211/DIN3337
- Solenoid flange: VDE/VDI 3845 (NAMUR)
- Accessory flange: VDE/VDI 3845 (NAMUR)
- European Directives: ATEX, PED and Machinery Directive.
- For RoHS2 compliance contact your nearest Emerson representative.
- SIL 3 rated according to IEC 61508-1-7:2010
- EAC Customs union: Compliance to Russian TR010 and TR012

Table 1. Actuator Weight

Actuator Model	Double Acting		Spring Return Springset N=6	
	lbs	Kg	lbs	Kg
RPE 25	3.1	1.4	3.5	1.6
RPE 40	4.6	2.1	5.1	2.3
RPE 65	6.2	2.8	7.3	3.3
RPE 100	7.7	3.5	9.5	4.3
RPE 150	10.8	4.9	14.6	6.6
RPE 200	13.2	6.0	18.3	8.3
RPE 350	22	10.2	32	14.5
RPE 600	44	20	57	26
RPE 950	58	26	89	41
RPE 1600	91	41	137	62
RPE 2500	141	64	221	100
RPE 4000	226	103	325	147

Table 2. Cycle time in seconds

Actuator Model	Spring Return		Double acting	
	Opening Stroke	Closing Stroke	Opening Stroke	Closing Stroke
RPE 25	0.5	0.4	0.5	0.4
RPE 40	0.6	0.5	0.6	0.5
RPE 65	0.7	0.5	0.6	0.6
RPE 100	0.8	0.6	0.8	0.7
RPE 150	1.0	0.8	0.9	0.8
RPE 200	1.3	0.9	1.0	1.0
RPE 350	1.9	1.3	1.4	1.5
RPE 600	3.2	1.9	2.2	2.2
RPE 950	6.6	2.2	2.4	2.0
RPE 1600	10.6	3.5	3.6	3.3
RPE 2500	16.9	5.7	5.8	5.2
RPE 4000	29.1	9.2	9.2	9.0

1. Test conditions:
2. Solenoid with flow capacity: 0.6 m3/hr
3. Pipe diameter: 6 mm
4. Medium: clean air
5. Supply pressure: 5.5 bar/80psi
6. Load: with average load
7. Stroke: 90°
8. Temperature: Room temperature

Table 3. Actuator air volumes and consumption

Actuator model	Actuator volumes:			Consumption per stroke (in liters, pressure in barg)					
	Maximum volume (in liters)			Outward Stroke			Inward Stroke		
	Central ¹ chamber	End cap ² chamber	Displace ³ volume	Double acting and Spring Return			Double acting only		
				2.0 barg	4.0 barg	8.0 barg	2.0 barg	4.0 barg	8.0 barg
RPE 25	0.14	0.20	0.08	0.36	0.64	1.2	0.48	0.88	1.7
RPE 40	0.26	0.37	0.15	0.67	1.2	2.2	0.89	1.6	3.1
RPE 65	0.40	0.56	0.22	1.02	1.8	3.4	1.3	2.4	4.7
RPE 100	0.6	0.9	0.3	1.5	2.7	5.0	2.0	3.8	7.2
RPE 150	1.0	0.8	0.5	2.4	4.3	8.1	2.1	3.6	6.7
RPE 200	1.3	1.0	0.7	3.2	5.7	11	2.8	4.9	9.1
RPE 350	2.1	1.9	1.2	5.5	9.8	18	5.0	8.8	16
RPE 600	3.6	3.3	2.1	9.4	17	31	8.7	15	28
RPE 950	4.9	4.6	3.2	13	23	43	12	22	40
RPE 1600	7.9	7.3	5.4	21	37	69	20	35	64
RPE 2500	12.6	11.9	8.3	34	59	109	32	56	104
RPE 4000	21.7	19.0	13.5	57	100	187	52	89	165

1. Notes:
2. 1. For Double-acting and Spring-return. Pistons at 90° outward position
3. 2. Only for Double-acting. Pistons at 0° inward position
4. 3. Stroke is 90°

**Central air chamber volume
Double-Acting and Spring-Return**

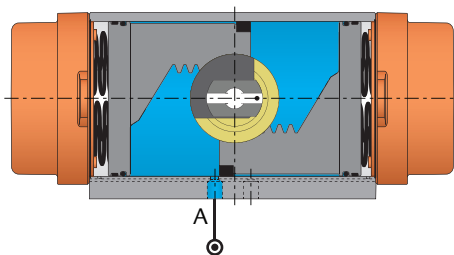

**End cap air chamber volume
Double-Acting only**

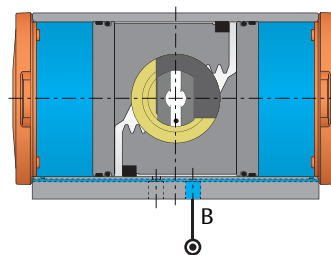

Construction, Parts and Materials RPE25-RPE600

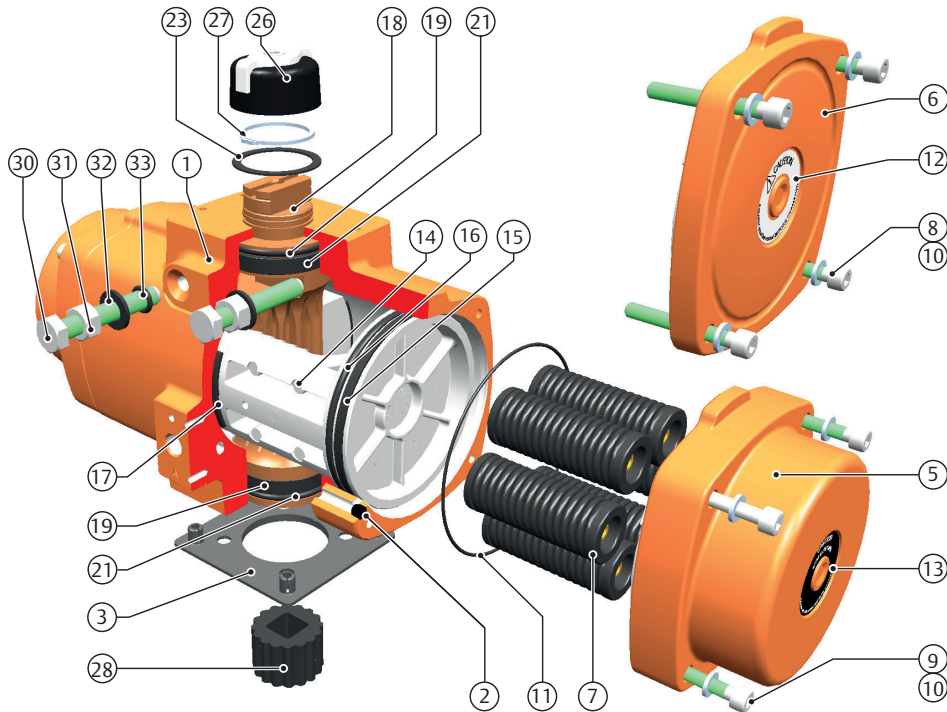

Notes:

- | | |
|------------------------------------------------------------------------------------------------------------------------------------------------------------------------------------------------------------------|-----------------------------------------------------------------------------------------------------------------------------------------------------------------------------------------------------------------------------------------------------|
| <ul style="list-style-type: none"> 1 Included in Service Kit. 2 Anodized and polyurethane powder coated. 3 Chromated 4 Hard anodized 5 Electrophoretic coated | <ul style="list-style-type: none"> 6 Deltatone® coated 7 Anodized 8 High end caps for double-acting and spring-return models up to size RPE100. Low end caps for double-acting models for sizes RPE150 and larger. |
|------------------------------------------------------------------------------------------------------------------------------------------------------------------------------------------------------------------|-----------------------------------------------------------------------------------------------------------------------------------------------------------------------------------------------------------------------------------------------------|

Pos.	Qty	Notes	Description	Material
1	1	2	House	Cast Aluminium alloy
2	2	1	B-port seal	Silicon rubber
3	1		Center plate (option)	Nylon PA6, Black
5	2	2, 8	End cap SR (DA)	Cast Aluminium alloy
6	2	2, 8	End cap DA	Cast Aluminium alloy
7	Max. 12	5	Spring cartridge	Spring steel
8	8		End cap screw DA	Stainless Steel
9	8		End cap screw SR	Stainless Steel
10	8		End cap screw washer	Stainless Steel
11	2	1	O-ring end cap	Nitrile rubber
12	2		Warning sticker DA	Polyester
13	2		Warning sticker SR	Polyester
14	2	3	Piston	Cast Aluminium alloy
15	2	1	Bearing piston	PTFE 25% carbon-filled
16	2	1	O-ring piston	Nitrile rubber
17	2	1	Bearing strip piston rack	POM
18	2	4	Pinion	High grade aluminium
19	2	1	Bearing pinion	POM
21	2	1	O-ring pinion	Nitrile rubber
23	1	1	Thrust bearing pinion	POM, black UV stabilized
26	1		Indicator assembly	ABS + stainless steel screw
27	1	1, 6	Circlip	Spring steel
28	1	7	Drive insert	Aluminium
30	2		Limit stop screw	Stainless steel
31	2		Limit stop nut	Stainless steel
32	2	1	Limit stop washer	PA66
33	2	1	O-ring limit stop	Nitrile rubber

Construction, Parts and Materials RPE950-RPE2500

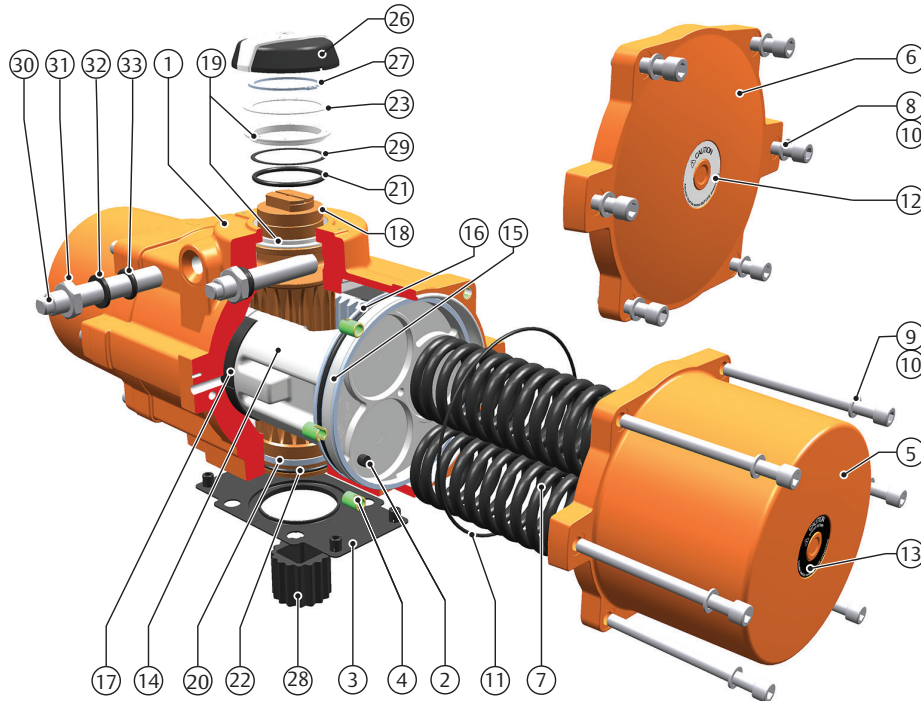

Notes:

- | | | | |
|---|-----------------------------------------|---|------------------------|
| 1 | Included in Service Kit. | 5 | Electrophoretic coated |
| 2 | Anodized and polyurethane powder coated | 6 | Deltatone® coated |
| 3 | Chromated | 7 | Anodized |
| 4 | Hard anodized | 8 | 8x for Size 950 |

Pos.	Qty.	Notes	Description	Material
1	1	2	House	Cast Aluminium alloy
2	2	1	B-port seal	Silicon rubber
3	1		Center plate (option)	Nylon PA6, Black
4	8/12	8	Thread insert	Steel
5	2	2	End cap SR	Cast Aluminium alloy
6	2	2	End cap DA	Cast Aluminium alloy
7	Max. 6	5	Springs	Spring steel
8	8/12	8	End cap screw DA	Stainless Steel
9	8/12	8	End cap screw SR	Stainless Steel
10	8/12	8	End cap screw washer	Stainless Steel
11	2	1	O-ring end cap	Nitrile rubber
12	2		Warning sticker DA	Polyester
13	2		Warning sticker SR	Polyester
14	2	3	Piston	Cast Aluminium alloy
15	2	1	Bearing piston	PTFE 25% carbon-filled
16	2	1	O-ring piston	Nitrile rubber
17	2	1	Bearing strip piston rack	POM
18	1	4	Pinion	High grade aluminium
19	2	1	Bearing pinion top	POM
20	1	1	Bearing pinion bottom	POM
21	1	1	O-ring pinion top	Nitrile rubber
22	1	1	O-ring pinion bottom	Nitrile rubber
23	1	1	Thrust bearing pinion	POM, black UV stabilized
26	1		Indicator assembly	ABS + stainless steel screw
27	1	1, 6	Circlip	Spring steel
28	1	7	Drive insert	Aluminium
29	1	1	Backup ring	POM
30	2		Limit stop screw	Stainless steel
31	2		Limit stop nut	Stainless steel
32	2	1	Limit stop washer	PA66
33	2	1	O-ring limit stop	Nitrile rubber

Construction, Parts and Materials RPE4000

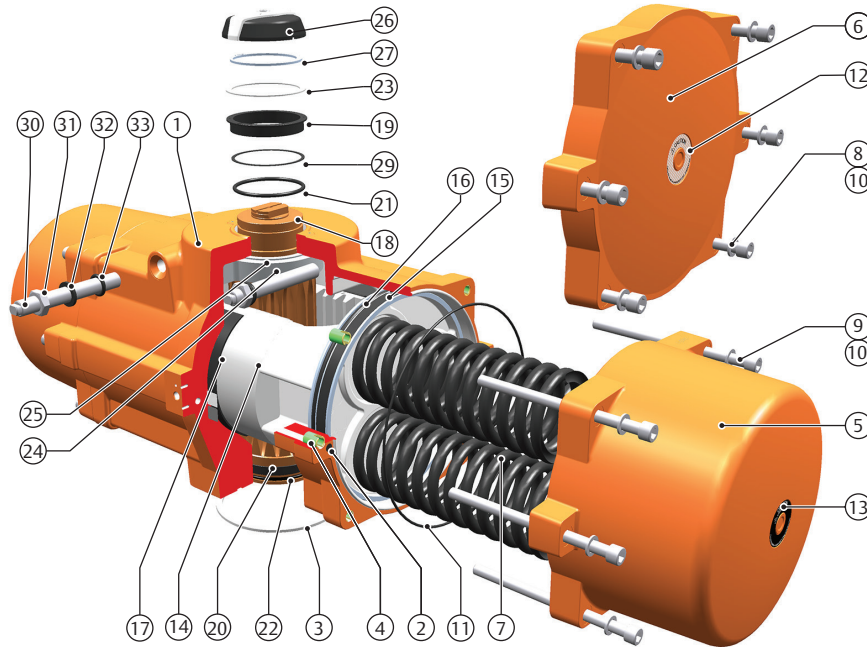

Notes:

- 1 Included in Service Kit.
- 2 Anodized and polyurethane powder coated.
- 3 Chromated
- 4 Hard anodized
- 5 Electrophoretic coated
- 6 Deltatone® coated

Pos.	Qty.	Notes	Description	Material
1	1	2	House	Cast Aluminium alloy
2	2	1	B-port seal	Silicon rubber
3	1		Center ring	Stainless Steel AISI 304
4	12		Thread insert	Steel
5	2	2	End cap SR	Cast Aluminium alloy
6	2	2	End cap DA	Cast Aluminium alloy
7	Max. 6	5	Springs	Spring steel
8	12		End cap screw DA	Stainless Steel
9	12		End cap screw SR	Stainless Steel
10	12		End cap screw washer	Stainless Steel
11	2	1	O-ring end cap	Nitrile rubber
12	2		Warning sticker DA	Polyester
13	2		Warning sticker SR	Polyester
14	2	3	Piston assembly	Cast Aluminium alloy
15	2	1	Bearing piston	PTFE 25% carbon-filled
16	2	1	O-ring piston	Nitrile rubber
17	2	1	Bearing strip piston rack	POM
18	1	4	Pinion	High grade aluminium
19	1	1	Bearing pinion top	POM
20	1	1	Bearing pinion bottom	POM
21	1	1	O-ring pinion top	Nitrile rubber
22	1	1	O-ring pinion bottom	Nitrile rubber
23	1	1	Thrust washer pinion	POM, black UV stabilized
24	1		Cam stroke adjustment	Steel
25	1	1	Cam thrust washer	POM, black UV stabilized
26	1		Indicator assembly	ABS + stainless steel screw
27	1	1, 6	Circlip	Spring steel
29	1	1	Backup ring	POM
30	2		Limit stop screw	Stainless steel
31	2		Limit stop nut	Stainless steel
32	2	1	Limit stop washer	PA66
33	2	1	O-ring limit stop	Nitrile rubber

Bettis RPE-Series Corrosion Protection System

Description

The corrosion protection system of standard Bettis RPE-Series pneumatic actuators consist of the following treatments or materials:

Electrophoretic finish on springs

Springs are protected from corrosion using an electrophoretic finish.

Anodize pre-treatment

The housing and end caps get an anodize pre-treatment prior to painting. The pre-treatment takes care of a perfect bonding of the paint layer to the aluminium housing and gives additional corrosion protection to the bore of the housing.

Powder coat

- Polyurethane powder coating for exterior use.
- The powder coating is applied cold using automatic electrostatic spray equipment and is cured for about 10 minutes at minimum 200°C (392°F) offering excellent light and weather resistance.
- The powder coating thickness is between 80 and 160 microns (3.15 and 6.3 mils).
- Good chemical resistance against most bases, acids, solvents, alkalis and oils at normal temperatures.
- Excellent exterior mechanical durability.
- The coating has passed a salt spray test according to ASTM B117 for 1,500 hours.

The powder coating is virtually solvent free, and therefore environmentally friendly.

High grade & hard anodized aluminium pinion

Actuators with high grade & hard anodized aluminium pinions, passed a 1,500 hours salt spray test. Optional stainless steel pinions are available for a higher corrosion resistance.

Stainless steel or Deltatone treated external steel parts

External parts are stainless steel or steel alloy with a Deltatone® treatment for optimum protection and durability.

The chemical and durability assessment.

All these components, treatments and finishes, including the durable pinion design, anodized surface finish, standard powder coat paint and Stainless steel treated external fasteners shows no decline of actuator functions up to 1,500 hours salt spray test.

Technical Data

Coating :	Polyurethane powder coating for exterior use.
Salt spray test :	ASTM B117: 1,500 hours
Color :	Orange (RAL 2009)
Materials: Housing:	Anodized aluminium alloy
Endcaps:	Anodized aluminium alloy
Pistons:	Chromated aluminium alloy
Pinion:	High grade aluminium alloy, hard anodized (Option: Stainless steel)
Springs:	Electrophoretic finish
Fasteners:	Stainless steel or alloy steel with Deltatone® treatment
Type Sticker:	Polyester
Application:	Standard Bettis RPE-Series pneumatic actuators

Table 1. Test result polyurethane powder coating

No	Item	Standard	Specification
1	Hardness	ASTM D3363 Pencil (Mitsubishi Uni)	H
2	Adhesion	ISO 2409, ASTM D3359 Cross hatch test (2mm)	Gt (0) 100% Adhesion
3	Impact test	ASTM D2794 5/8" Ball (direct)	Min. 60 lb.in without detachment
4	Bend test	DIN 53152, ISO1519, ASTM D522	Min 3.2 mm without cracking
5	Resistance to humid atmospheres	ASTM D543 3%, H2s04, 4 hours	No Blistering
6	Alkali resistance	ASTM D543 10%, NaOH, 4 hours	No Blistering
7	Water resistance	DIN 500017, min.	No Blistering
8	UV resistance	ASTM G 154 (UVB-313)	Excellent color and gloss retention

1. This data sheet contains general information as supplied by the paint supplier and describes typical properties for the coating.

Assembly Codes Bettis RPE-Series actuators

Spring-return actuators

Assembly code: CW

= Standard, Clockwise-to-Close rotation
= Fail-to-Close

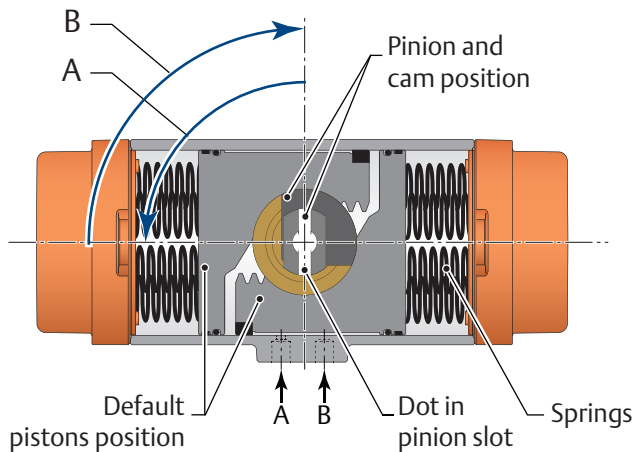

Assembly code: CC

= Reverse, Counterclockwise-to-Open
= Fail-to-Open

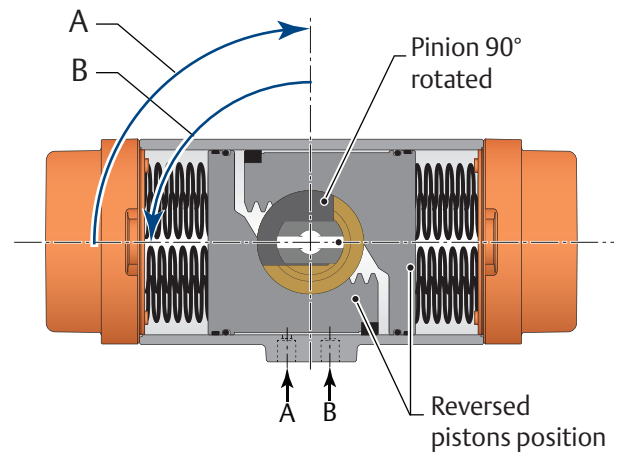

A = Central air chamber pressurized
B = Spring stroke

Double-acting actuators

Assembly code: CW

= Standard, Clockwise-to-Close rotation

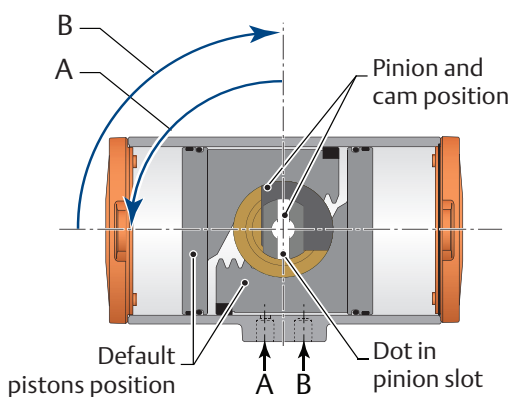

Assembly code: CC

= Reverse, Counterclockwise-to-Open

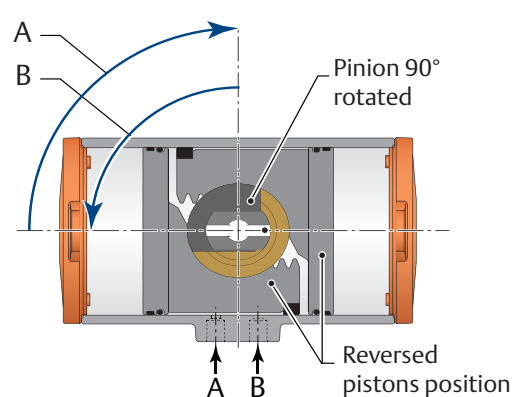

A = Central air chamber pressurized
B = End cap air chambers pressurized

All views are from above. Pistons are shown in inward position.

Actuator Torque - Spring-Return (Nm)

Actuator Size	Spring set nr.	Spring Stroke Torque (Nm)		Air Torque (Nm)																	
				SUPPLY PRESSURE																	
				3.0 barg		3.5 barg		4.0 barg		4.5 barg		5.0 barg		5.5 barg		6.0 barg		7.0 barg		8.0 barg	
Start	End	Start	End	Start	End	Start	End	Start	End	Start	End	Start	End	Start	End	Start	End	Start	End		
RPES 25	10	4	2	12	10	14	13	17	15	19	17	21	20	24	22	26	25	31	29	36	34
	20	7	4	9	6	12	9	14	11	16	13	19	16	21	18	24	21	28	25	33	30
	30	11	7	7	2	9	4	11	7	14	9	16	12	19	14	21	17	26	21	31	26
	40	14	9	-	-	-	-	9	3	11	5	14	8	16	10	18	12	23	17	28	22
	50	18	11	-	-	-	-	-	-	9	1	11	4	14	6	16	8	21	13	26	18
	60	21	13	-	-	-	-	-	-	-	-	-	-	11	2	13	4	18	9	23	14
RPES 40	10	7	4	22	19	26	24	31	28	36	33	40	37	45	42	49	46	58	55	67	64
	20	13	8	17	12	22	16	26	21	31	25	35	30	40	34	44	39	53	48	62	57
	30	20	12	12	4	17	9	21	13	26	18	31	22	35	27	40	31	49	40	58	49
	40	26	17	-	-	12	1	17	6	21	10	26	15	30	19	35	24	44	33	53	42
	50	33	21	-	-	-	-	-	-	17	3	21	7	26	12	30	16	39	25	48	34
	60	39	25	-	-	-	-	-	-	-	-	-	-	21	4	25	9	34	18	43	27
RPES 65	10	10	6	33	29	40	36	47	43	54	50	61	57	68	63	75	70	88	84	102	98
	20	20	13	26	17	33	24	40	31	47	38	53	45	60	52	67	59	81	72	95	86
	30	31	19	19	5	25	12	32	19	39	26	46	33	53	40	60	47	74	61	87	74
	40	41	26	-	-	-	-	25	8	32	14	39	21	46	28	52	35	66	49	80	63
	50	51	32	-	-	-	-	-	-	24	3	31	10	38	17	45	23	59	37	73	51
	60	61	39	-	-	-	-	-	-	-	-	-	-	31	5	38	12	52	25	65	39
RPES 100	10	15	9	49	43	60	53	70	64	80	74	90	84	100	94	111	104	131	125	151	145
	20	30	19	39	26	49	36	59	47	69	57	79	67	90	77	100	87	120	108	141	128
	30	44	28	28	9	38	19	48	30	59	40	69	50	79	60	89	70	109	91	130	111
	40	59	37	-	-	27	2	38	13	48	23	58	33	68	43	78	53	99	74	119	94
	50	74	47	-	-	-	-	-	-	37	6	47	16	57	26	68	36	88	57	108	77
	60	89	56	-	-	-	-	-	-	-	-	-	-	47	9	57	19	77	40	98	60
RPES 150	10	24	15	79	69	96	86	112	102	128	118	145	135	161	151	177	167	210	200	243	233
	20	47	30	62	42	79	59	95	75	111	91	128	108	144	124	160	140	193	173	226	206
	30	71	44	45	15	62	32	78	48	94	64	111	81	127	97	143	113	176	146	209	179
	40	94	59	-	-	45	5	61	21	77	37	94	54	110	70	126	86	159	119	192	152
	50	118	74	-	-	-	-	-	-	60	10	77	26	93	43	109	59	142	92	175	124
	60	141	89	-	-	-	-	-	-	-	-	-	-	76	16	92	32	125	65	158	97
RPES 200	10	33	21	108	94	131	117	153	139	175	161	198	184	220	206	242	228	287	273	332	318
	20	65	41	85	57	107	79	129	102	152	124	174	146	196	169	219	191	263	236	308	280
	30	98	62	61	19	83	42	106	64	128	86	150	109	173	131	195	153	240	198	284	243
	40	131	82	-	-	-	-	82	26	104	49	127	71	149	93	171	116	216	161	261	205
	50	163	103	-	-	-	-	-	-	81	11	103	34	125	56	148	78	192	123	237	168
	60	196	124	-	-	-	-	-	-	-	-	-	-	102	18	124	41	169	85	213	130
RPES 350	10	56	35	189	165	227	204	266	243	305	281	344	320	383	359	422	398	499	476	577	553
	20	112	70	148	101	187	139	226	178	265	217	303	256	342	295	381	334	459	411	537	489
	30	168	106	108	36	146	75	185	114	224	153	263	192	302	231	341	269	418	347	496	425
	40	224	141	-	-	106	11	145	50	184	89	222	127	261	166	300	205	378	283	455	360
	50	280	176	-	-	-	-	-	-	143	24	182	63	221	102	260	141	337	218	415	296
	60	335	211	-	-	-	-	-	-	-	-	-	-	180	38	219	77	297	154	374	232
RPES 600	10	96	60	320	279	386	345	452	411	518	477	584	543	650	609	716	675	848	807	980	939
	20	192	121	251	169	317	235	383	301	449	367	515	433	581	499	647	565	779	697	911	829
	30	287	181	181	59	247	125	313	191	379	257	445	323	511	389	577	455	709	587	841	719
	40	383	241	-	-	178	15	244	81	310	147	376	213	442	279	508	345	640	477	772	609
	50	479	302	-	-	-	-	-	-	241	37	307	103	373	169	439	235	571	367	703	499
	60	575	362	-	-	-	-	-	-	-	-	-	-	303	59	369	125	501	257	633	389

Actuator Torque - Spring-Return (Nm)

Actuator Size	Spring set in.	Spring Stroke Torque (Nm)		Air Torque (Nm)																	
				SUPPLY PRESSURE																	
				3.0 barg		3.5 barg		4.0 barg		4.5 barg		5.0 barg		5.5 barg		6.0 barg		7.0 barg		8.0 barg	
Start	End	Start	End	Start	End	Start	End	Start	End	Start	End	Start	End	Start	End	Start	End	Start	End		
RPES 950	10	121	77	481	427	579	525	677	623	775	721	873	819	971	917	1069	1015	1265	1211	1461	1407
	20	242	155	385	276	483	374	581	472	679	570	777	668	875	766	973	864	1169	1060	1365	1256
	30	363	232	288	125	386	223	484	321	582	418	680	516	778	614	876	712	1072	908	1268	1104
	40	484	309	-	-	289	71	387	169	485	267	583	365	681	463	779	561	975	757	1171	953
	50	605	387	-	-	-	-	-	-	389	116	487	214	585	312	683	410	879	606	1075	802
	60	726	464	-	-	-	-	-	-	-	-	390	63	488	161	586	259	782	455	978	651
RPES 1600	10	207	129	808	710	972	874	1136	1038	1300	1202	1465	1367	1629	1531	1793	1695	2122	2023	2450	2352
	20	415	258	647	450	811	615	975	779	1139	943	1304	1107	1468	1271	1632	1436	1960	1764	2289	2093
	30	622	387	486	191	650	355	814	520	978	684	1142	848	1307	1012	1471	1176	1799	1505	2128	1833
	40	830	516	-	-	489	96	653	260	817	425	981	589	1146	753	1310	917	1638	1246	1967	1574
	50	1037	644	-	-	-	-	-	-	656	165	820	330	984	494	1149	658	1477	986	1806	1315
	60	1244	773	-	-	-	-	-	-	-	-	659	70	823	234	988	399	1316	727	1644	1056
RPES 2500	10	295	180	1276	1133	1530	1388	1785	1642	2039	1896	2294	2151	2548	2405	2803	2660	3312	3169	3820	3678
	20	589	361	1050	765	1305	1019	1559	1274	1814	1528	2068	1783	2323	2037	2577	2292	3086	2801	3595	3309
	30	884	541	825	397	1079	651	1334	905	1588	1160	1843	1414	2097	1669	2352	1923	2860	2432	3369	2941
	40	1178	722	-	-	854	283	1108	537	1363	792	1617	1046	1871	1301	2126	1555	2635	2064	3144	2573
	50	1473	902	-	-	-	-	883	169	1137	423	1391	678	1646	932	1900	1187	2409	1696	2918	2205
	60	1768	1083	-	-	-	-	-	-	911	55	1166	310	1420	564	1675	819	2184	1327	2693	1836
RPES 4000	10	473	299	2063	1846	2476	2259	2889	2672	3302	3085	3715	3498	4128	3911	4541	4324	5367	5150	6193	5976
	20	945	598	1690	1255	2103	1668	2516	2081	2929	2494	3342	2907	3755	3320	4168	3733	4994	4559	5820	5385
	30	1418	896	1316	664	1729	1077	2142	1490	2555	1903	2968	2316	3381	2729	3794	3142	4620	3968	5446	4794
	40	1891	1195	943	73	1356	486	1769	899	2182	1312	2595	1725	3008	2138	3421	2551	4247	3377	5073	4203
	50	2363	1494	-	-	-	-	1395	309	1808	722	2221	1135	2634	1548	3047	1961	3873	2787	4699	3613
	60	2836	1793	-	-	-	-	-	-	1435	131	1848	544	2261	957	2674	1370	3500	2196	4326	3022

Note:

1. Emerson recommends that the valve manufacturer supply the maximum required torque values (Including any adjustments or suggested safety factors for valve service conditions or application).
2. Additionally, the valve manufacturer must identify at which position(s) and direction(s) of rotation (Counterclockwise or Clockwise) these maximum requirements occur.
3. If in doubt, or you require any assistance with sizing actuators, do not hesitate to contact your nearest Emerson's Actuation Technologies Division representative.

Figure 1. Spring-Return torque diagram

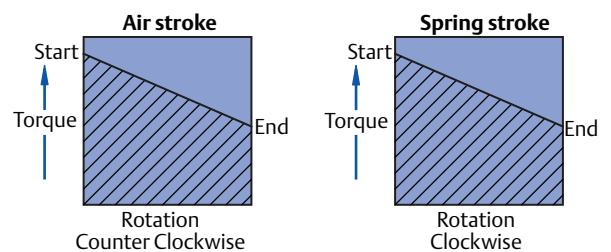

Actuator Torque - Spring-Return (lbf.in)

Actuator Size	Spring set nr.	Spring Stroke Torque (lbf.in)		Air Stroke Torque (lbf.in)															
				SUPPLY PRESSURE															
		Start	End	40 psig		50 psig		60 psig		70 psig		80 psig		90 psig		100 psig		120 psig	
RPES 25	10	31	20	93	80	123	109	152	139	181	168	211	198	240	227	270	257	329	316
	20	63	39	70	44	100	73	129	103	159	132	188	162	218	191	247	221	306	280
	30	94	59	48	8	77	37	107	67	136	96	166	126	195	155	225	185	283	244
	40	125	79	-	-	-	-	84	31	113	60	143	90	172	119	202	149	261	208
	50	156	99	-	-	-	-	-	-	91	24	120	54	150	83	179	113	238	172
	60	188	118	-	-	-	-	-	-	-	-	98	18	127	47	157	77	216	136
RPES 40	10	58	37	175	150	230	206	285	261	341	316	396	371	451	427	506	482	617	592
	20	116	73	133	84	188	139	243	195	299	250	354	305	409	360	464	415	575	526
	30	174	110	91	18	146	73	201	128	257	183	312	239	367	294	422	349	533	459
	40	231	146	-	-	-	-	159	62	214	117	270	172	325	227	380	283	491	393
	50	289	183	-	-	-	-	-	-	172	50	228	106	283	161	338	216	449	327
	60	347	220	-	-	-	-	-	-	-	-	186	39	241	94	296	150	407	260
RPES 65	10	90	57	265	227	349	311	434	395	518	479	602	564	686	648	770	732	939	900
	20	181	114	200	123	284	207	368	291	452	376	537	460	621	544	705	628	873	796
	30	271	171	134	19	219	103	303	188	387	272	471	356	555	440	639	524	808	693
	40	361	228	-	-	-	-	237	84	322	168	406	252	490	336	574	420	742	589
	50	452	285	-	-	-	-	-	-	256	64	340	148	424	232	509	317	677	485
	60	542	341	-	-	-	-	-	-	-	-	275	44	359	129	443	213	612	381
RPES100	10	131	83	394	339	518	463	643	588	767	712	892	836	1016	961	1141	1085	1390	1334
	20	262	166	299	188	423	313	548	437	672	562	797	686	921	811	1046	935	1295	1184
	30	392	248	203	38	328	162	452	287	577	411	701	536	826	660	950	785	1199	1034
	40	523	331	-	-	-	-	357	136	482	261	606	385	731	510	855	634	1104	883
	50	654	414	-	-	-	-	-	-	387	110	511	235	636	359	760	484	1009	733
	60	785	497	-	-	-	-	-	-	-	-	416	85	540	209	665	334	914	583
RPES 150	10	208	131	633	544	832	743	1031	942	1231	1142	1430	1341	1629	1540	1829	1740	2227	2138
	20	416	262	482	304	681	504	881	703	1080	902	1279	1102	1479	1301	1678	1500	2077	1899
	30	625	393	332	65	531	264	730	464	930	663	1129	862	1328	1062	1528	1261	1926	1660
	40	833	524	-	-	-	-	580	224	779	424	979	623	1178	823	1377	1022	1776	1421
	50	1041	654	-	-	-	-	-	-	629	185	828	384	1027	583	1227	783	1626	1181
	60	1249	785	-	-	-	-	-	-	-	-	678	145	877	344	1076	543	1475	942
RPES 200	10	289	182	862	739	1135	1012	1408	1285	1681	1558	1954	1831	2226	2104	2499	2376	3045	2922
	20	578	364	653	407	926	680	1198	953	1471	1226	1744	1499	2017	1771	2290	2044	2836	2590
	30	867	547	443	75	716	348	989	621	1262	894	1535	1166	1808	1439	2080	1712	2626	2258
	40	1156	729	-	-	-	-	780	289	1052	561	1325	834	1598	1107	1871	1380	2417	1926
	50	1445	911	-	-	-	-	-	-	843	229	1116	502	1389	775	1662	1048	2207	1593
	60	1734	1093	-	-	-	-	-	-	-	-	906	170	1179	443	1452	716	1998	1261
RPES 350	10	495	312	1503	1293	1978	1767	2452	2241	2926	2716	3400	3190	3874	3664	4348	4138	5296	5086
	20	990	624	1145	724	1619	1199	2093	1673	2567	2147	3041	2621	3515	3095	3990	3569	4938	4517
	30	1485	936	786	156	1261	630	1735	1104	2209	1578	2683	2052	3157	2526	3631	3000	4579	3948
	40	1979	1248	-	-	-	-	1376	535	1850	1009	2324	1483	2798	1957	3272	2431	4221	3380
	50	2474	1560	-	-	-	-	-	-	1492	440	1966	914	2440	1388	2914	1863	3862	2811
	60	2969	1872	-	-	-	-	-	-	-	-	1607	346	2081	820	2555	1294	3504	2242
RPES 600	10	848	534	2551	2190	3356	2996	4162	3801	4968	4607	5773	5413	6579	6218	7385	7024	8996	8635
	20	1695	1068	1937	1216	2743	2021	3548	2827	4354	3633	5160	4438	5965	5244	6771	6050	8382	7661
	30	2543	1601	1324	241	2129	1047	2935	1853	3741	2658	4546	3464	5352	4270	6158	5075	7769	6687
	40	3391	2135	-	-	-	-	2321	878	3127	1684	3933	2490	4738	3295	5544	4101	7155	5712
	50	4238	2669	-	-	-	-	-	-	2513	710	3319	1515	4125	2321	4930	3127	6542	4738
	60	5086	3203	-	-	-	-	-	-	-	-	2706	541	3511	1346	4317	2152	5928	3763

Actuator Torque - Spring-Return (lbf.in)

Actuator Size	Spring set nr.	Spring Stroke Torque (lbf.in)		Air Stroke Torque (lbf.in)															
				SUPPLY PRESSURE															
				40 psig		50 psig		60 psig		70 psig		80 psig		90 psig		100 psig		120 psig	
Start	End	Start	End	Start	End	Start	End	Start	End	Start	End	Start	End	Start	End	Start	End		
RPES 950	10	1070	685	3842	3360	5038	4556	6234	5752	7430	6948	8627	8144	9823	9340	11019	10536	13411	12929
	20	2141	1369	2986	2022	4182	3218	5379	4414	6575	5610	7771	6806	8967	8002	10163	9198	12555	11591
	30	3211	2054	2130	683	3327	1880	4523	3076	5719	4272	6915	5468	8111	6664	9307	7860	11699	10252
	40	4282	2738	-	-	2471	541	3667	1738	4863	2934	6059	4130	7255	5326	8451	6522	10844	8914
	50	5352	3423	-	-	-	-	2811	399	4007	1596	5203	2792	6400	3988	7596	5184	9988	7576
	60	6423	4108	-	-	-	-	-	-	3152	257	4348	1454	5544	2650	6740	3846	9132	6238
RPES 1600	10	1835	1141	6447	5579	8452	7583	10456	9588	12461	11592	14466	13597	16470	15602	18475	17606	22484	21615
	20	3671	2281	5022	3284	7026	5289	9031	7294	11035	9298	13040	11303	15044	13307	17049	15312	21058	19321
	30	5506	3422	3596	990	5600	2995	7605	4999	9610	7004	11614	9008	13619	11013	15623	13018	19632	17027
	40	7342	4562	-	-	4175	700	6179	2705	8184	4709	10188	6714	12193	8719	14198	10723	18207	14732
	50	9177	5703	-	-	-	-	4753	411	6758	2415	8763	4420	10767	6424	12772	8429	16781	12438
	60	11013	6844	-	-	-	-	-	-	-	-	7337	2125	9342	4130	11346	6135	15355	10144
RPES 2500	10	2607	1597	10204	8941	13310	12047	16416	15153	19523	18259	22629	21366	25735	24472	28841	27578	35054	33791
	20	5215	3194	8208	5681	11314	8788	14420	11894	17526	15000	20633	18106	23739	21213	26845	24319	33058	30532
	30	7822	4791	6211	2422	9318	5528	12424	8635	15530	11741	18636	14847	21743	17953	24849	21060	31062	27272
	40	10430	6388	-	-	7321	2269	10428	5375	13534	8482	16640	11588	19747	14694	22853	17800	29065	24013
	50	13037	7985	-	-	-	-	8432	2116	11538	5222	14644	8329	17750	11435	20857	14541	27069	20754
	60	15645	9582	-	-	-	-	-	-	9542	1963	12648	5069	15754	8176	18860	11282	25073	17494
RPES 4000	10	4183	2645	16495	14572	21537	19613	26578	24655	31620	29696	36661	34738	41703	39780	46744	44821	56828	54904
	20	8366	5289	13189	9343	18231	14384	23273	19426	28314	24467	33356	29509	38397	34550	43439	39592	53522	49675
	30	12550	7934	9884	4114	14925	9155	19967	14197	25008	19238	30050	24280	35092	29321	40133	34363	50216	44446
	40	16733	10578	-	-	11620	3926	16661	8968	21703	14009	26744	19051	31786	24092	36827	29134	46911	39217
	50	20916	13223	-	-	-	-	13355	3739	18397	8780	23439	13822	28480	18863	33522	23905	43605	33988
	60	25099	15867	-	-	-	-	-	-	15091	3551	20133	8593	25174	13634	30216	18676	40299	28759

Notes:

- Emerson recommends that the valve manufacturer supply the maximum required torque values (Including any adjustments or suggested safety factors for valve service conditions or application).
- Additionally, the valve manufacturer must identify at which position(s) and direction(s) of rotation (Counter Clock Wise or Clock Wise) these maximum requirements occur.
- If in doubt, or if you require any assistance with sizing actuators, do not hesitate to contact your nearest Emerson's Actuation Technologies Division representative.

Figure 1. Spring Return torque diagram

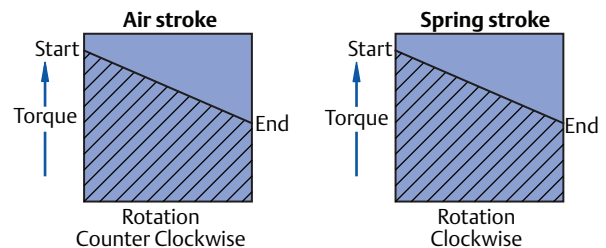

Actuator Torque - Double-Acting (Nm)

Actuator Size	Torque in Nm Supply Pressure (barg)										
	2	3	3.5	4	4.5	5	5.5	6	6.5	7	8
RPED 25	9	13	16	18	20	23	25	27	29	32	36
RPED 40	17	25	29	34	38	42	47	51	55	59	68
RPED 65	25	38	45	51	58	64	71	77	84	90	103
RPED 100	38	57	66	76	86	95	105	115	124	134	153
RPED 150	60	91	106	122	137	153	168	183	199	214	245
RPED 200	82	124	146	167	188	209	230	251	272	293	335
RPED 350	143	216	253	290	326	363	400	436	473	510	583
RPED 600	243	368	430	492	554	617	679	741	804	866	991
RPED 950	368	557	651	746	840	935	1029	1124	1218	1312	1501
RPED 1600	617	934	1092	1250	1408	1566	1725	1883	2041	2199	2516
RPED 2500	956	1447	1692	1937	2182	2427	2673	2918	3163	3408	3899
RPED 4000	1552	2348	2746	3144	3542	3940	4338	4736	5134	5532	6327

Notes:

1. Emerson recommends that the valve manufacturer supply the maximum required torque values (Including any adjustments or suggested safety factors for valve service conditions or application).
2. Additionally, the valve manufacturer must identify at which position(s) and direction(s) of rotation (Counter Clock Wise or Clock Wise) these maximum requirements occur.
3. If in doubt, or if you require any assistance with sizing actuators, do not hesitate to contact your nearest Emerson's Actuation Technologies Division representative.

Figure 1. Double acting torque diagram

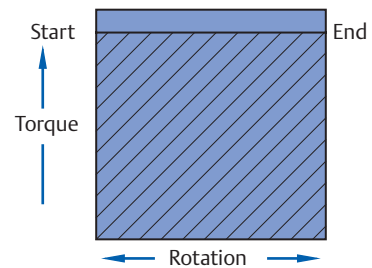

Actuator Torque - Double-Acting (lbf.in)

Actuator Size	Torque in lbf.in Supply pressure (psig)												
	30	35	40	45	50	55	60	70	75	80	90	100	120
RPED 25	81	95	109	123	137	151	165	193	207	220	248	276	332
RPED 40	153	179	205	231	257	283	309	361	387	413	466	518	622
RPED 65	233	272	312	352	392	431	471	550	590	630	709	789	948
RPED 100	344	403	461	520	579	638	696	814	873	931	1049	1166	1401
RPED 150	551	645	739	833	927	1021	1115	1304	1398	1492	1680	1868	2244
RPED 200	754	883	1011	1140	1269	1398	1527	1784	1913	2042	2299	2557	3072
RPED 350	1310	1534	1758	1981	2205	2429	2653	3100	3324	3547	3995	4442	5337
RPED 600	2226	2606	2987	3367	3747	4127	4508	5268	5648	6028	6789	7549	9070
RPED 950	3374	3950	4527	5103	5679	6255	6832	7984	8560	9137	10289	11442	13747
RPED 1600	5654	6620	7586	8552	9517	10483	11449	13380	14346	15312	17243	19175	23038
RPED 2500	8762	10259	11755	13252	14748	16245	17741	20734	22231	23727	26720	29713	35699
RPED 4000	14221	16650	19079	21508	23937	26365	28794	33652	36081	38510	43368	48225	57941

Notes:

1. Emerson recommends that the valve manufacturer supply the maximum required torque values (Including any adjustments or suggested safety factors for valve service conditions or application).
2. Additionally, the valve manufacturer must identify at which position(s) and direction(s) of rotation (Counter Clock Wise or Clock Wise) these maximum requirements occur.
3. If in doubt, or if you require any assistance with sizing actuators, do not hesitate to contact your nearest Emerson's Actuation Technologies Division representative.

Figure 2. Double acting torque diagram

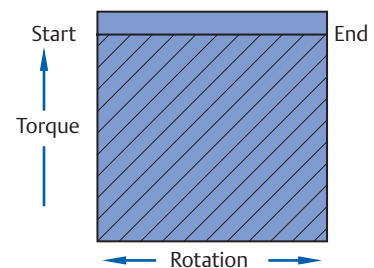

Sizing of Rack & Pinion actuators

Sizing is the selection procedure to select the right size of actuator on a valve with a given torque characteristic. This data sheet gives brief samples on how to size actuators and which data is needed.

Torque characteristics of valves

Bettis RPE-Series actuators are commonly used to operate butterfly-, ball- and plug valves. The below instructions are intended for these valve applications, but can also be used for other quarter turn applications.

Figure 1. Generic torque characteristic of a valve

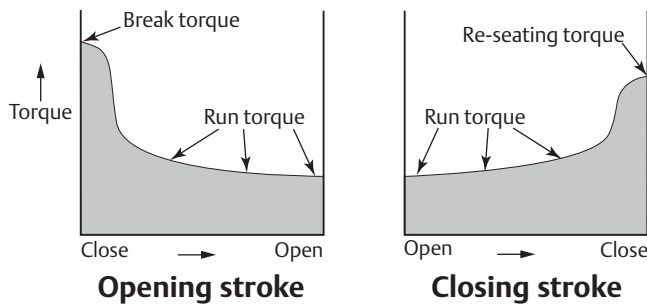

Valve torque values and safety factors

Emerson recommends that the valve manufacturer supply the maximum required and allowed torque values (Including any adjustments or suggested safety factors for valve service conditions or application).

Additionally, the valve manufacturer must identify at which position(s) and direction(s) of rotation (Counterclockwise or Clockwise) these maximum requirements occur.

If in doubt, or you require any assistance with sizing actuators, do not hesitate to contact your nearest Emerson's Valve Automation representative.

Sizing Double-Acting actuators

Figure 2. Double-Acting torque characteristic

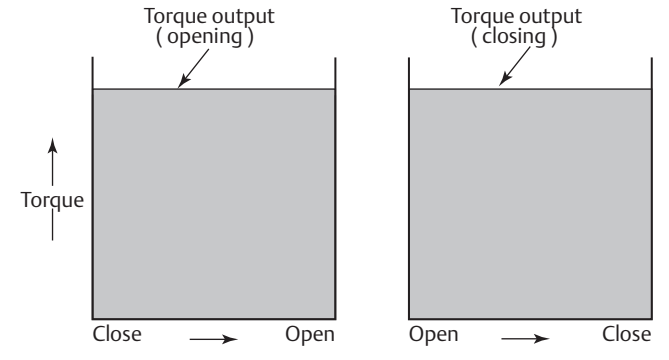

Sample calculation of Double-Acting sizing

- Publish valve break torque: 40 Nm 354 lbf.in
- Publish maximum stem torque: 105 Nm 929 lbf.in
- Recommended safety factor: 1.2 (20%)
- Minimum supply pressure: 5.5 bar 80 psi
- Maximum supply pressure: 6.5 bar 94 psi

Calculation:

1. Because the recommended safety factor is 1.2 the sizing torque will be $40 \times 1.2 = 48 \text{ Nm}$ ($354 \times 1.2 = 425 \text{ lbf.in}$).
2. Lookup in the Double-Acting torque table, in the 5.5 bar column (or 80 psi column), from top down, the first actuator size that generates more than 48 Nm (or 425 lbf.in).
3. Size RPED65 is the first actuator that supplies more than
 - a. 48 Nm (71 Nm) at 5.5 bar.
 - b. 425 lbf.in (630 lbf.in.) at 80 PSI.
4. The maximum torque output of a RPED65 is 84 Nm (743 lbf.in). This is lower than the maximum stem torque of 105Nm.

Conclusion

Because RPED65 supplies more torque than the sizing torque (see point 3) and less than the maximum stem torque (see point 4), size RPED65 is suitable to operate this valve.

Sizing Spring-Return actuators

Figure 3. Spring-to-Close configuration

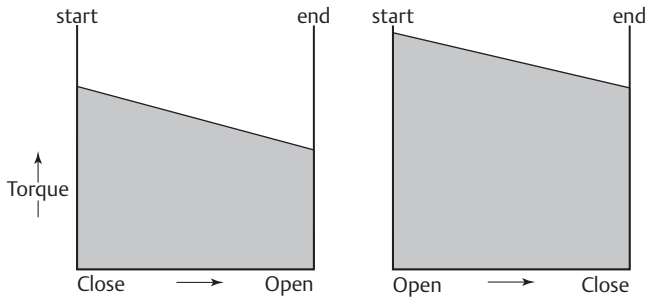

Table 1. For Fail-to Close actuators applies:

Actuator stroke:	Valve Stroke:
Air-Start torque	> Break torque and
Air-End torque	> Run open torque and
Spring-Start torque	> Run open torque and
Spring-End torque	> Re-seat torque

Table 2. For Fail-to Open actuators applies:

Actuator stroke:	Valve Stroke:
Spring-Start torque	> Break torque and
Spring-End torque	> Run torque and
Air-Start torque	> Run torque and
Air-End torque	> Re-seat torque

Sample calculation Spring-Return sizing for a Spring-to-Close application

- Published valve torques
 - Break torque: 150 Nm 1328 lbf.in
 - Run torque opening: 45 Nm 398 lbf.in
 - Run torque closing: 45 Nm 398 lbf.in
 - Re-seating torque; 90 Nm 797 lbf.in
- Publish maximum stem torque: 375 Nm 3496 lbf.in
- Recommended safety factor: 1.5 (50%)
- Minimum supply pressure: 5.5 bar 80 psi
- Maximum supply pressure: 6.0 bar 87 psi

Calculation:

1. Because the recommended safety factor is 1.5 the sizing torques will be:
 - Break 150 Nm x 1.5 = 225 Nm 1991 lbf.in
 - Run open 45 Nm x 1.5 = 67.5 Nm 597 lbf.in
 - Run close 45 Nm x 1.5 = 67.5 Nm 597 lbf.in
 - Re-seat 90 Nm x 1.5 = 135 Nm 1195 lbf.in
2. Lookup in the Spring-Return torque table, in the "spring end" torque column, from top down, the first actuator size that generates more than 135 Nm (or 1195 lbf.in) of re-seat torque.
3. Size RPES350 with spring set 4 is the first actuator that supplies more spring end torque (149 Nm or 1655 lbf.in).
4. Check now for the other three positions whether the actuator torque exceeds the valve torques.

Actuator stroke:	Valve Stroke:
Air-Start: 252 Nm	> Break open: 225 Nm.
Air-End: 157 Nm	> Run open: 67.5 Nm.
Spring-Start: 232 Nm	> Run close: 67.5 Nm.
Spring-End: 149 Nm	> Re-seat: 135 Nm

5. The maximum torque output of a RPES350 with springset 4 at maximum pressure of 6 bar is 291 Nm (2575 lbf.in). This is lower than the maximum stem torque of 375 Nm (3496 lbf.in).

Conclusion

Because RPES350 n=40 supplies more torque than the sizing torque (see point 3) and less than the maximum stem torque (see point 5), size RPES350 n=40 is suitable to operate this valve.

Note:

- If the first found actuator does not exceed the valve torque at all the positions, check the next size actuator.
- If the next size actuator does exceed the valve torque at all the positions, but fails at maximum stem torque check whether the same actuator but with a higher springset (i.e. 50 instead of 40) does meet this requirement.

Spring (Cartridge) placement

Bettis RPE-Series Spring return actuators are supplied with springs on each side of the actuator. Throughout the RPE-Series size range, there are two different spring designs:

- Sizes RPE25 to RPE600 have 6 springs on each side (see figure 1).
- Sizes RPE950 to RPE4000 have 3 springs on each side (see figure 2).

Check below figures to see where to place the spring cartridges in case of spring set conversion.

When replacing spring cartridges in a spring-return actuator, ensure that the cartridges are replaced in their identical position from where they were removed.

Before assembling the spring cartridges and end caps, make sure that the pistons are completely inwards.

Figure 1. Spring placement sizes RPE25 to RPE600

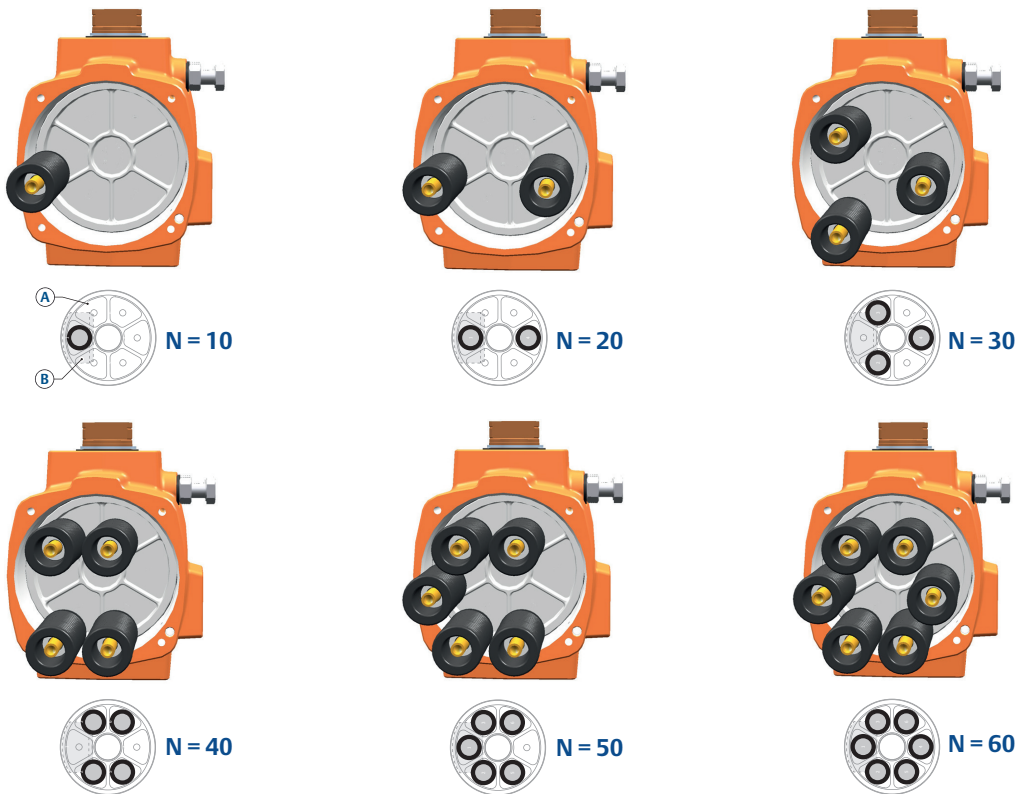

A = Piston top view
B = Position of piston gear rack

Figure 2. Spring placement sizes RPE 950 to RPE4000

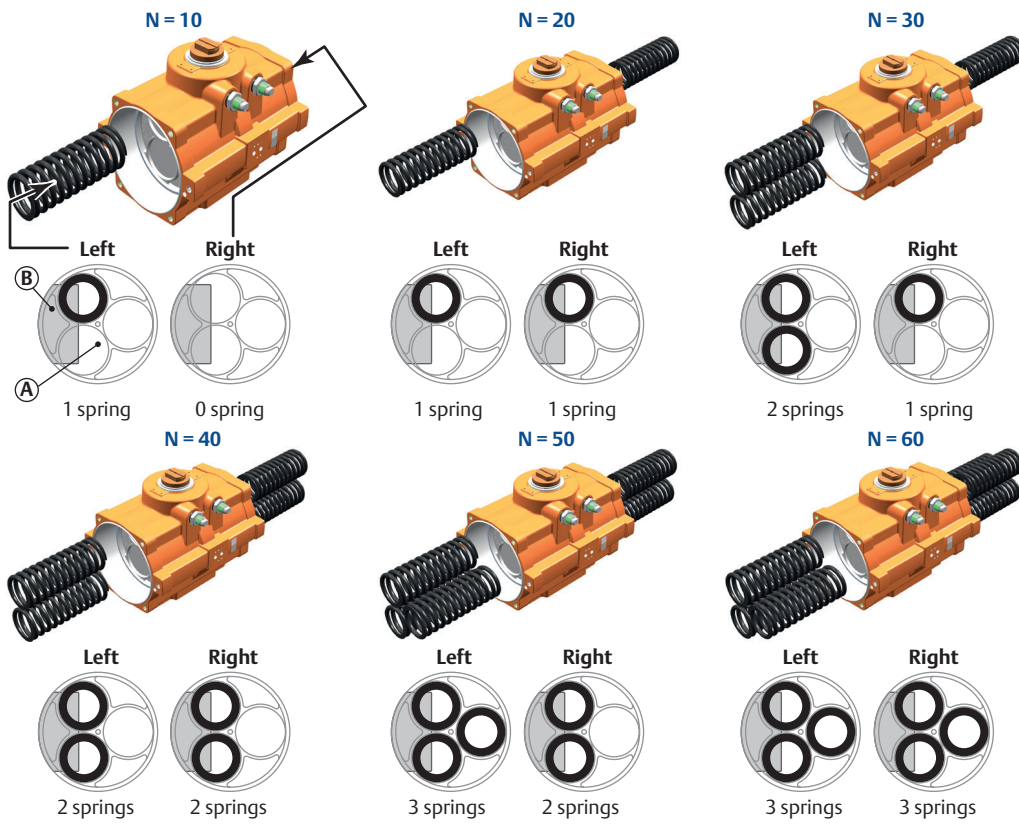

A = Piston top view
 B = Position of piston gear rack

Dimensions - Metric (DIN3337)

Envelope Dimensions - Solenoid and Top Mounting Interface Sizes 25 - 600

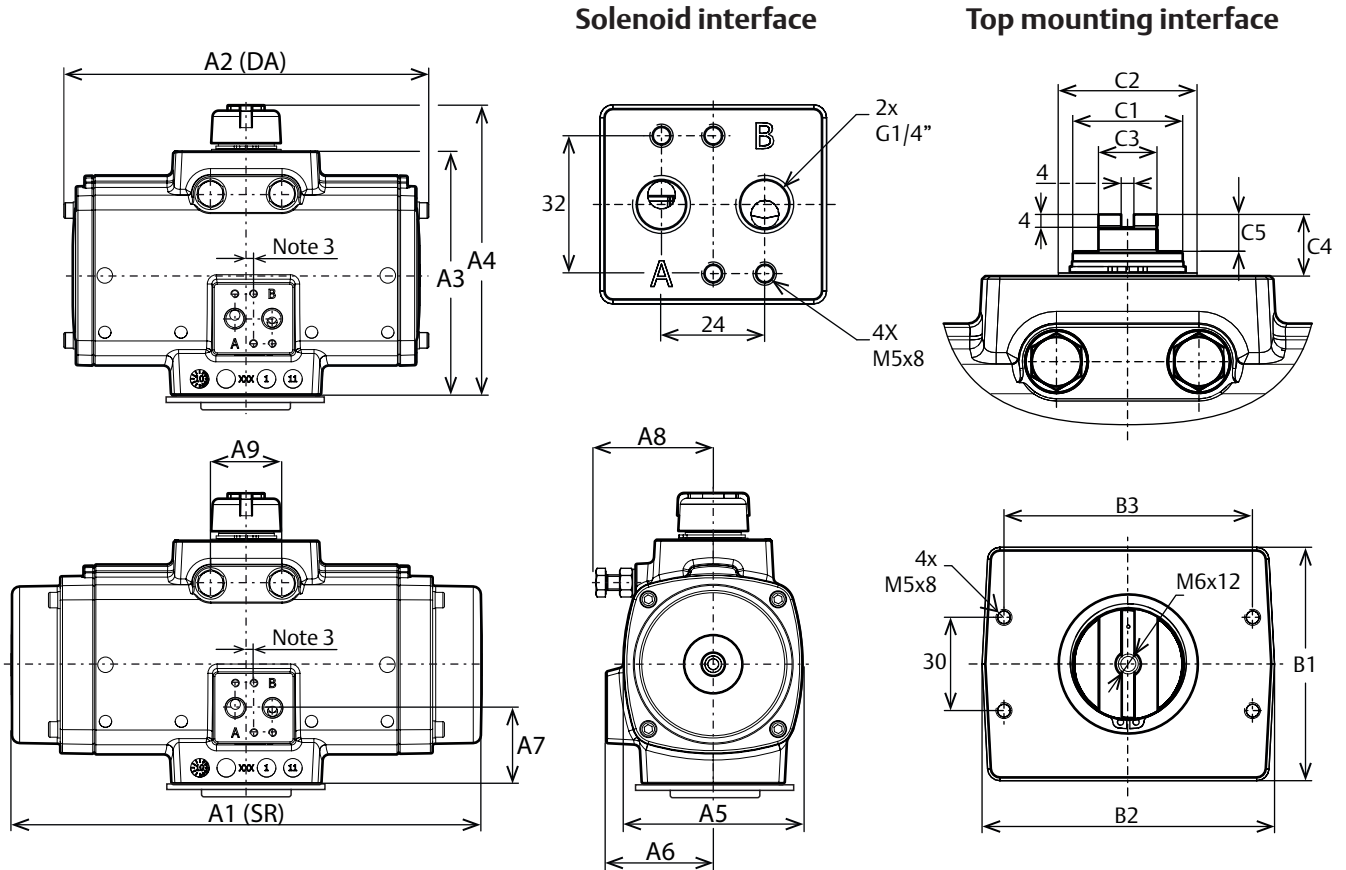

Notes:

1. DA = Double-Acting, SR = Spring-Return
2. Solenoid interface and top mounting interface according to VDI/VDE3845 (NAMUR)
3. The solenoid drilling pattern is shifted 4 mm for size 0025 and 2 mm for size 0040 vs the centerline of the actuator.

Dim in. mm	Actuator size							
	0025	0040	0065	0100	0150	0200	0350	0600
A1	166	192	217	247	304	362	385	476
A2	166	192	217	247	235	265	284	356
A3	91	112	124	131	157	163	201	248
A4	119	139	151	158	185	191	230	292
A5	68	82	92	103	116	124	161	195
A6	49	55	58	64	69	72	85	102
A7	30	34	38	38	49	49	42	67
A8	48	58	69	69	75	87	109	132
A9	18	25	27	28	46	46	46	60
B1	43	45	50	60	75	75	85	98
B2	94	94	94	97	94	94	100	148
B3	80	80	80	80	80	80	80	130
C1	16	22	22	22	34	36	36	55
C2	23	30	30	35	45	45	45	65
C3	14	14	14	14	19	19	19	36
C4	20	20	20	20	20	20	20	30
C5	12	12	12	12	12	12	12	10

Dimensions - Metric (DIN3337)

Envelope Dimensions - Solenoid and Top Mounting Interface Sizes 950 - 4000

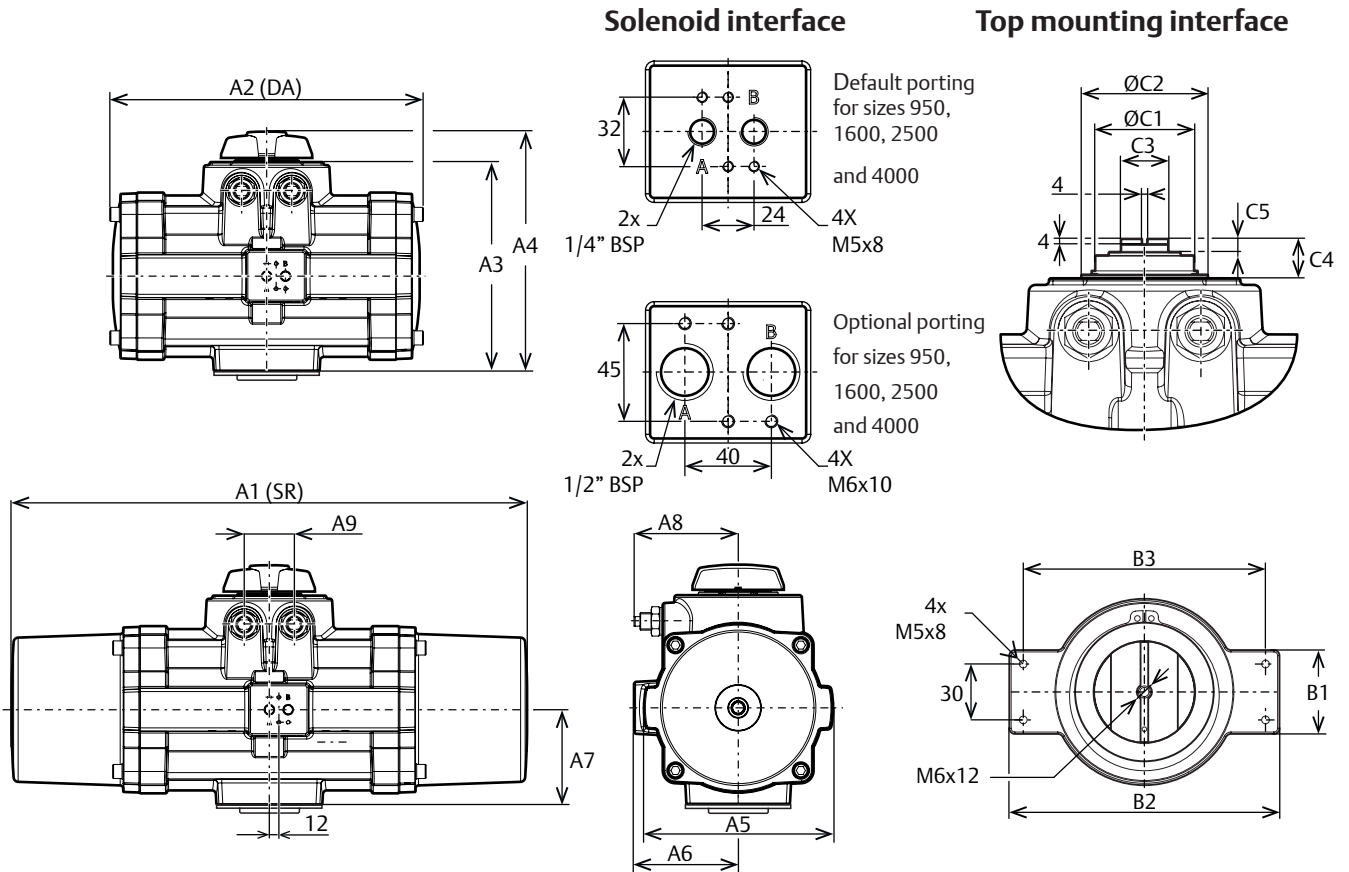

Notes:

1. DA = Double-Acting, SR = Spring-Return
2. Solenoid interface and top mounting interface according to VDI/VDE3845 (NAMUR)
3. The solenoid drilling pattern is shifted 12 mm for sizes 0950 to 4000 vs the centerline of the actuator.
4. The numbers in brackets are for actuators with 1/2" ports.

Dim in.	Actuator size			
mm	0950	1600	2500	4000
A1	658	732	877	959
A2	400	462	550	649
A3	268	302	354	389
A4	305	339	392	427
A5	239	306	350	400
A6	131	149	170	196
A7	121	137 (140) ⁴	157 (160) ⁴	184 (186) ⁴
A8	131	156	181	175
A9	64	85	102	184
B1	45	45	45	45
B2	145	145	145	145
B3	130	130	130	130
C1	65	75	95	96
C2	83	96	115	115
C3	36	36	36	36
C4	30	30	30	30
C5	10	10	10	10

Dimensions - Metric (ISO5211)

Valve Flange and Drive Details Sizes 25 - 4000

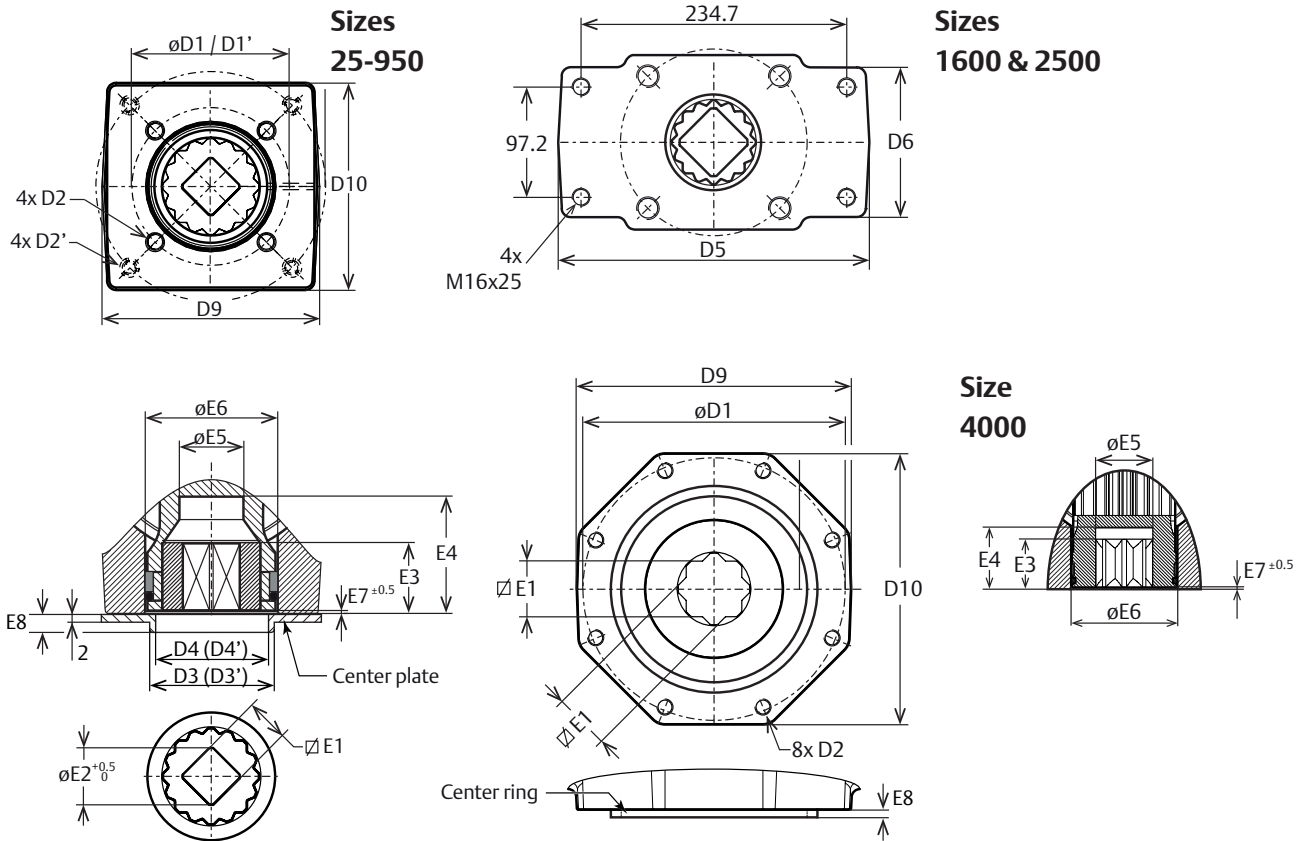

Notes:

1. Flange and square drive according to ISO 5211
2. F25* = For sizes 1600 and 2500 drilling pattern 234.6 x 97.2 represent 4 holes of a F25 drilling pattern.
3. Size 4000 has 2x inner square E1 in the pinion bottom instead of inserts
4. Drilling patterns DIN 1 are standard. Drilling patterns DIN 2 are optional.

Dim in.	Actuator size											
	0025	0040	0065	0100	0150	0200	0350	0600	0950	1600	2500	4000
DIN 1	F05	F05	F05	F07	F07	F10	F10	F12	F14	F16	F16	F25
D1	50	50	50	70	70	102	102	125	140	165	165	254
D2	M6x10	M6x10	M6x10	M8x13	M8x13	M10x15	M10x15	M12x18	M16x25	M20x20	M20x20	M16x25
D3	35	35	35	55	55	70	70	85	100	130	130	200
D4	29	32	32	40	50	54	54	68	75	95	95	120
DIN 2	F03	F07	F07	F05	F10	F07	F07	F10	F10	F25*	F25*	F16
D1'	36	70	70	50	102	70	70	102	102	-/-	-/-	165
D2'	M5x8	M8x13	M8x13	M6x10	M10x15	M8x13	M8x13	M10x15	M10x15	-/-	-/-	M20x20
D3'	-	40	40	32	54	50	50	-/-	-/-	-/-	-/-	-/-
D4'	-	55	55	35	70	55	55	-/-	-/-	-/-	-/-	-/-
D9	50	68	68	66	97	94	94	118	135	280	280	273
D10	48	65	65	63	92	90	94	113	130	132	132	269
E1 Max	11.08	14.08	14.08	17.08	17.08	22.10	22.10	27.11	36.16	46.16	46.16	55.24
E1 Min	11.00	14.00	14.00	17.00	17.00	22.00	22.00	27.00	36.00	46.00	46.00	55.00
E2	14	18	18	25	26	28	36	36	58.2	60.2	60.2	72.2
E3	15	15	15	18	28	28	28	28	48.5	59.5	59.5	61.5
E4	34	34	34	34	50	50	50	50	65.5	81.5	81.5	76.75
E5	14	18	21	24	29	32	32	37	48	60	60	73
E6	25	35	35	38	57	57	57	68	86	104	125	133
E7	1	1	1	1	1	1	1	1	1	1	1	1
E8	5	5	5	5	5	5	5	5	6	7	7	2.5

Dimensions - Metric (ISO5211)

Envelope Dimensions - Solenoid and Top Mounting Interface Sizes 25 - 600

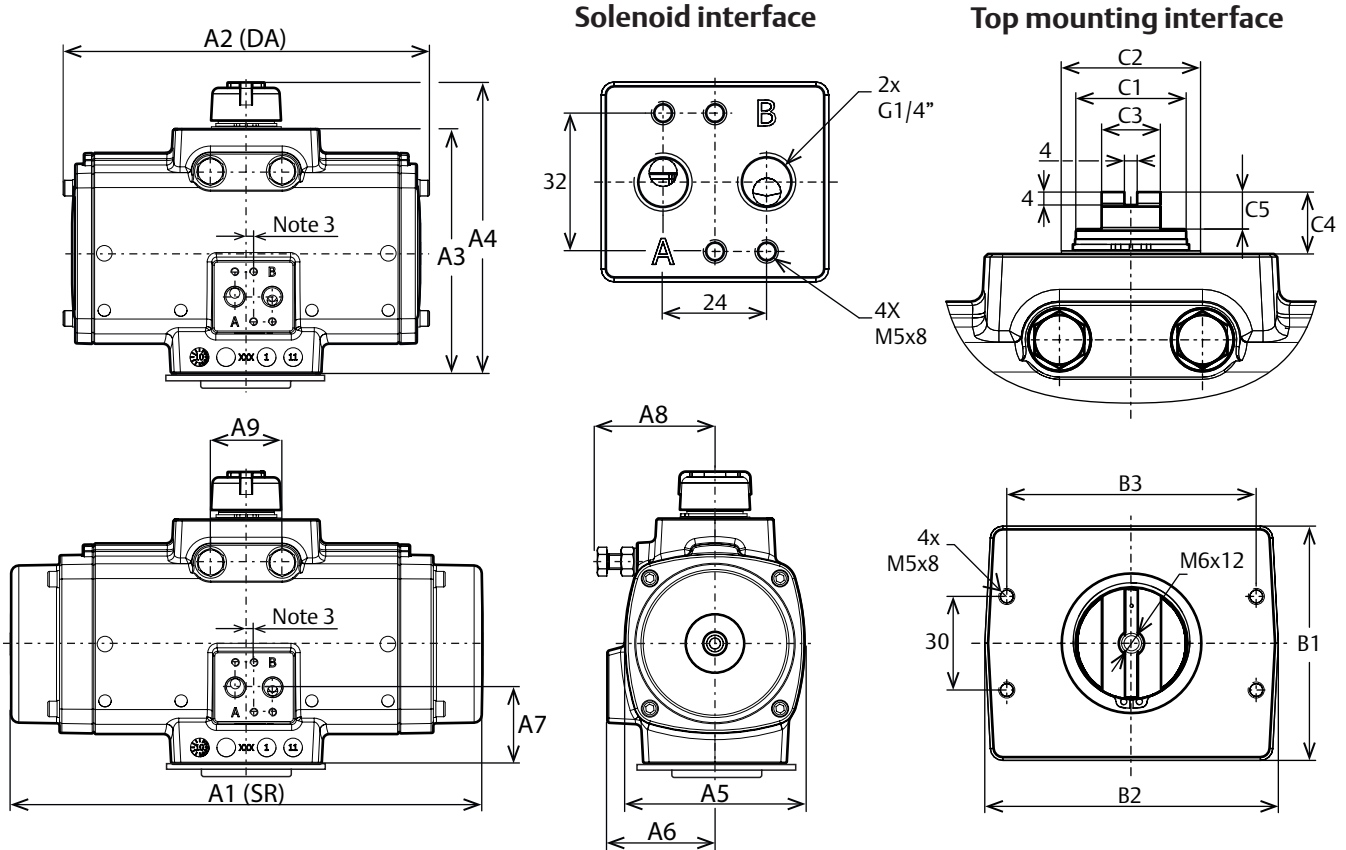

Notes:

1. DA = Double-Acting, SR = Spring-Return
2. Solenoid interface and top mounting interface according to VDI/VDE3845 (NAMUR)
3. The solenoid drilling pattern is shifted 4 mm for size 0025 and 2 mm for size 0040 vs the centerline of the actuator.

Dim in. mm	Actuator size							
	0025	0040	0065	0100	0150	0200	0350	0600
A1	166	192	217	247	304	362	385	476
A2	166	192	217	247	235	265	284	356
A3	91	112	124	131	157	163	201	248
A4	119	139	151	158	185	191	230	292
A5	68	82	92	103	116	124	161	195
A6	49	55	58	64	69	72	85	102
A7	30	34	38	38	49	49	42	67
A8	48	58	69	69	75	87	109	132
A9	18	25	27	28	46	46	46	60
B1	43	45	50	60	75	75	85	98
B2	94	94	94	97	94	94	100	148
B3	80	80	80	80	80	80	80	130
C1	16	22	22	22	34	36	36	55
C2	23	30	30	35	45	45	45	65
C3	14	14	14	14	19	19	19	36
C4	20	20	20	20	20	20	20	30
C5	12	12	12	12	12	12	12	10

Dimensions - Metric (ISO5211)

Envelope Dimensions - Solenoid and Top Mounting Interface Sizes 950 - 4000

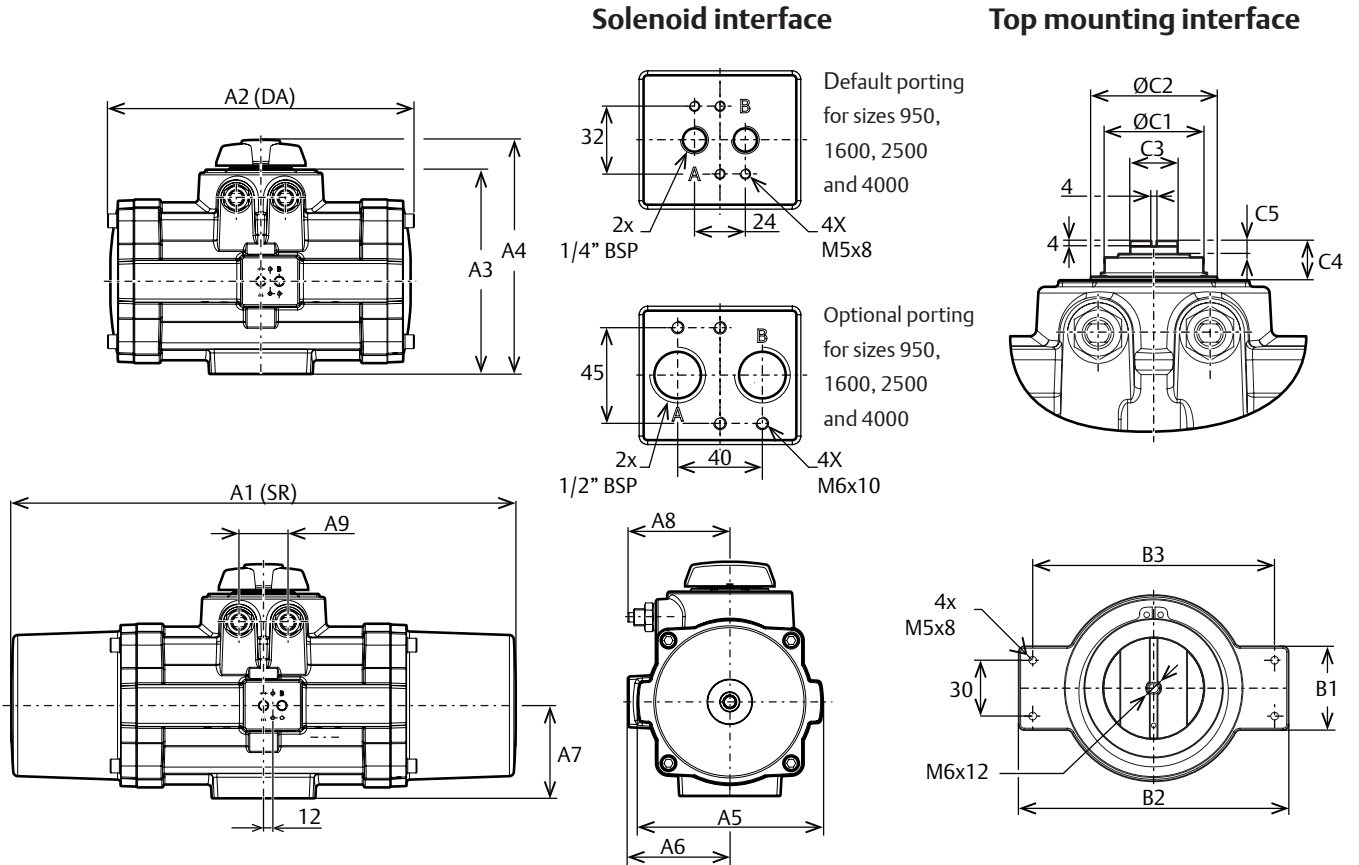

Notes:

1. DA = Double-Acting, SR = Spring-Return
2. Solenoid interface and top mounting interface according to VDI/VDE3845 (NAMUR)
3. The solenoid drilling pattern is shifted 12 mm for sizes 0950 to 4000 vs the centerline of the actuator.
4. The numbers in brackets are for actuators with 1/2" ports.

Dim in. mm	Actuator size			
	0950	1600	2500	4000
A1	658	732	877	959
A2	400	462	550	649
A3	268	302	354	389
A4	305	339	392	427
A5	239	306	350	400
A6	131	149	170	196
A7	121	137 (140) ⁴	157 (160) ⁴	184 (186) ⁴
A8	131	156	181	175
A9	64	85	102	184
B1	45	45	45	45
B2	145	145	145	145
B3	130	130	130	130
C1	65	75	95	96
C2	83	96	115	115
C3	36	36	36	36
C4	30	30	30	30
C5	10	10	10	10

Dimensions - Metric (ISO5211)

Valve Flange and Drive Details Sizes 25 - 4000

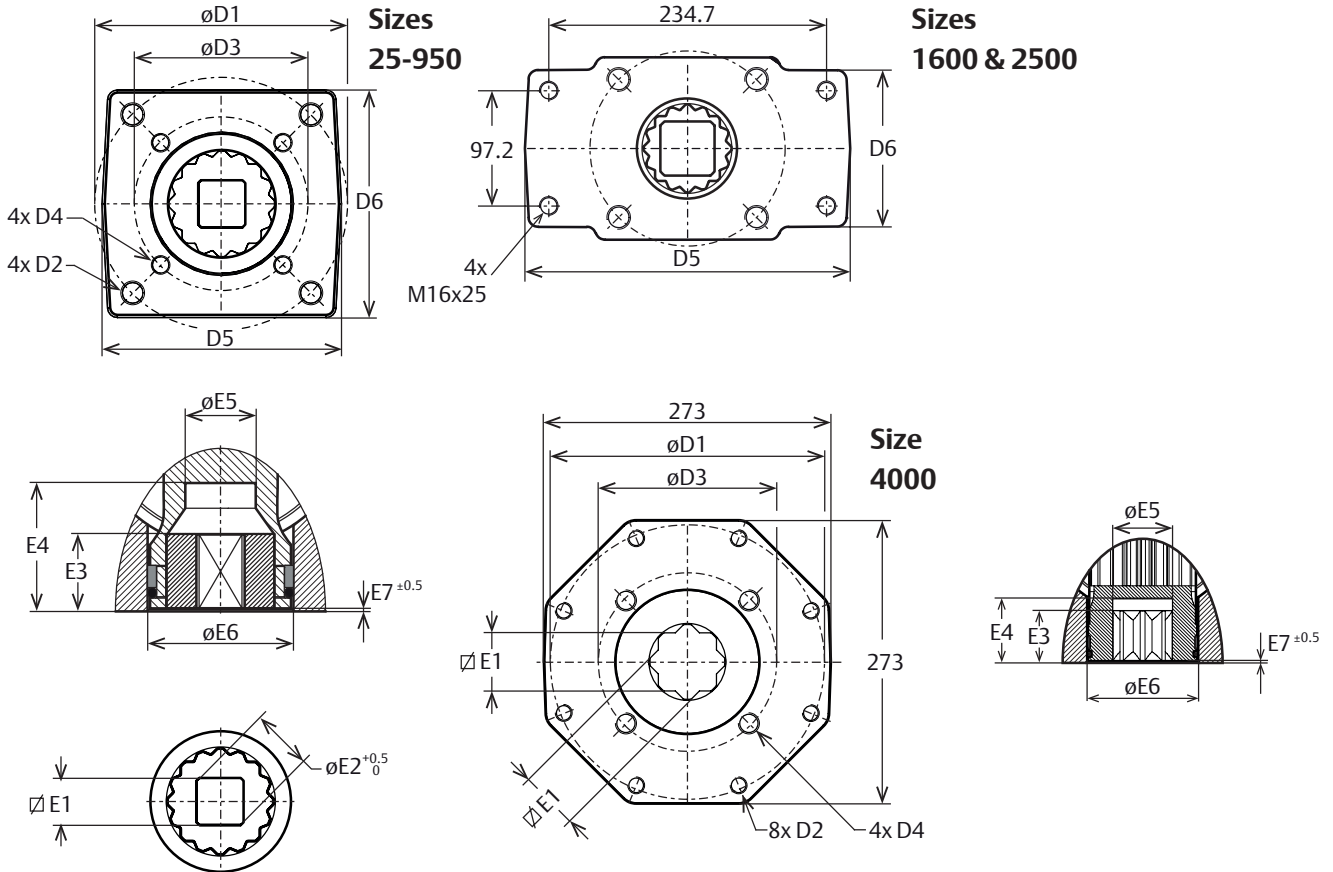

Notes:

1. Flange and square drive according to ISO 5211
2. F25* = For sizes 1600 and 2500 drilling pattern 234.6 x 97.2 represent 4 holes of a F25 drilling pattern.
3. Size 4000 has 2x inner square E1 in the pinion bottom instead of inserts

Dim in.	Actuator size											
mm	0025	0040	0065	0100	0150	0200	0350	0600	0950	1600	2500	4000
ISO 1	F05	F07	F07	F07	F10	F10	F10	F12	F14	F16	F16	F25
D1	50	70	70	70	102	102	102	125	140	165	165	254
D2	M6x10	M8x13	M8x13	M8x13	M10x15	M10x15	M10x15	M12x18	M16x25	M20x20	M20x20	M16x25
ISO 2	F03	F05	F05	F05	F07	F07	F07	F10	F10	F25*	F25*	F16
D3	36	50	50	50	70	70	70	102	102	-/-	-/-	165
D4	M5x8	M6x10	M6x10	M6x10	M8x13	M8x13	M8x13	M10x16	M10x16	-/-	-/-	M20x20
D5	50	68	68	66	97	94	94	118	135	280	280	273
D6	48	65	65	63	92	90	94	113	130	132	132	269
E1 Max.	11.08	14.08	14.08	19.08	19.08	22.10	27.11	27.11	36.16	46.16	46.16	55.24
E1 Min.	11.00	14.00	14.00	19.00	19.00	22.00	27.00	27.00	36.00	46.00	46.00	55.00
E2	14.1	18.1	18.1	25.2	25.5	28.2	36.2	36.2	58.2	60.2	60.2	72.2
E3	15	15	15	18	27.5	27.5	27.5	27.5	48.5	59.5	59.5	61.5
E4	34	34	34	34	50	50	50	50	65.5	81.5	81.5	76.75
E5	14.1	18.1	21.1	23.5	28.5	32.1	32.1	36.5	48	60	60	73
E6	24.5	34.5	34.5	38	56.5	56.5	56.5	67.5	86	104	125	133
E7	0.5	1	1	1	1.2	1.2	1.2	1.2	1	1	1	1

Drive Inserts

Key features

- Drive inserts allow actuators to be directly mounted to valves
- Eliminates the need for a bracket and coupling type mounting kit.
- The use of drive inserts significantly cuts the cost of the valve/actuator assembly.
- Standard actuators are fitted with square drive inserts
- Special inserts may have oversized or undersized squares, double-D and shaft key way forms.

Description

The Bettis RPE-Series actuators are fitted with drive inserts. These drive inserts allow actuators to be directly mounted onto suitable valves in accordance with ISO 5211 and eliminates the need for a bracket and coupling type mounting kit. The use of direct mounts significantly cuts the cost of the valve/actuator assembly.

Standard actuators are fitted with square drive inserts in accordance with ISO 5211. The ISO 5211 standard covers parallel and diagonal oriented inner squares (as per old DIN 3337 standard).

Additionally, a wide variety of other inserts are also available. Special inserts may have oversized or undersized squares, double-D and shaft key way forms.

Drive inserts can be supplied on factory built actuators or as loose items and are easily replaceable at distributor or end user level.

Where direct mounts are not possible, for instance on valves with exposed grand packing, the use of inserts often simplifies the design of the mounting kit.

- Material: Aluminium alloy
- Finish : Anodized

Notes:

1. Actuator size RPE4000 does not have inserts. This actuator size has two inner squares (diagonally and parallel oriented) directly in the bottom of the pinion.
2. Page 2 and 3 shows an overview of the default insert sizes and the most common square shaped insert sizes. Please contact your local Bettis representative for all available insert sizes.

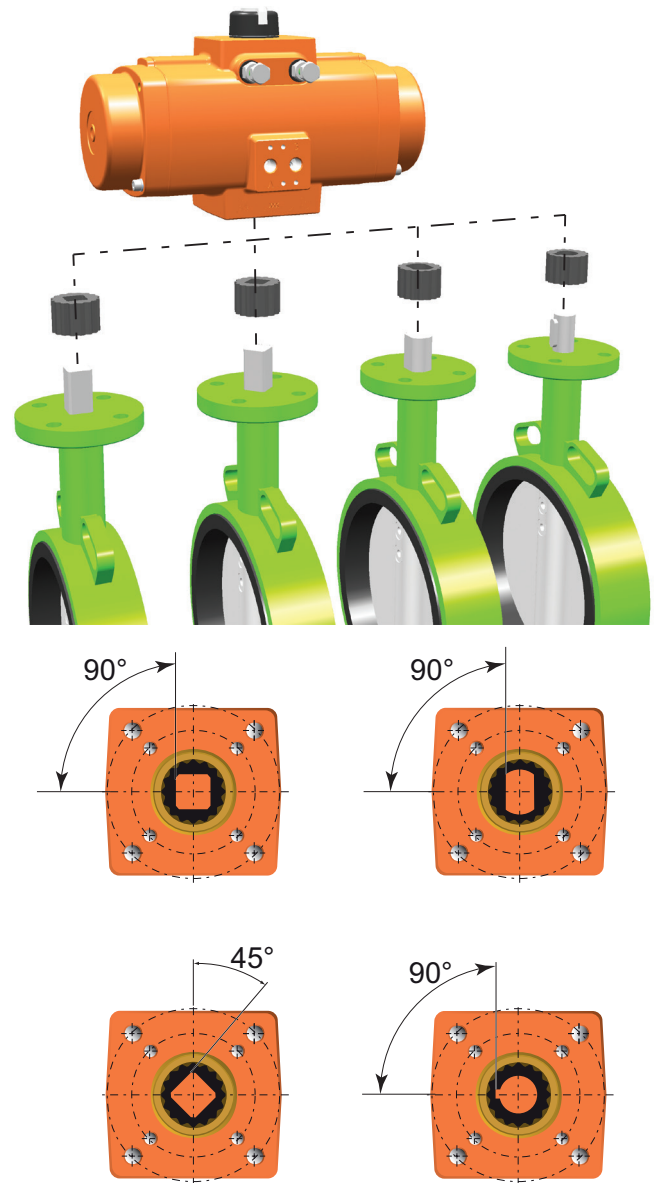

Table 3. Metric drive square overview

Dim. in mm	Inserts with inner-square-dimensions per actuator type										
	0025	0040/ 0065	0100	0150	0200	0350	0600	0950	1600	2500	4000
Standard square drive dimensions											
Type	Insert	Insert	Insert	Insert	Insert	Insert	Insert	Insert	Insert	Insert	Star drive
Parallel ■	11	14	19	19	22	27	27	36	46	46	55
Diagonal ◆	11	14	17	17	22	22	27	36	46	46	55
Optional square insert dimensions (Notes 1)											
	8	8	9	9	9	9	9	14	22	22	No insert
	9	9	10	10	10	10	10	19	27	27	
	10	10	11	11	11	11	11	22	30	30	
		11	12	12	12	12	12	27	36	36	
		12	14	14	14	14	14	30			
		16	16	16	16	16	16				
				22	17	17	17				
				24	19	19	19				
				25	24	24	22				
				27	25	25	24				
					27		25				
Maximum adaptor/valve stem dimensions											
M1	34.5	34.5	34.5	50	50	50	52	64.5	81	81	No insert
M2	-	-	27.5	-	37	37	-	-	-	-	
P1	14.1	18.1/ 21.2	23.5	28.5	32.2	32.2	36.8	48.3	60.2	60.2	
P2	-	-	25.2	-	36.3	36.3	-	-	-	-	
Sq. max.	11	16	19	27	27	27	27	36	46	46	
D max.	13.8	21	23.6	33.6	33.6	33.6	33.6	45	60	60	

1. Above table shows an overview of the default insert sizes and the most common square shaped insert sizes. Please contact your local Bettis representative for all available insert sizes.

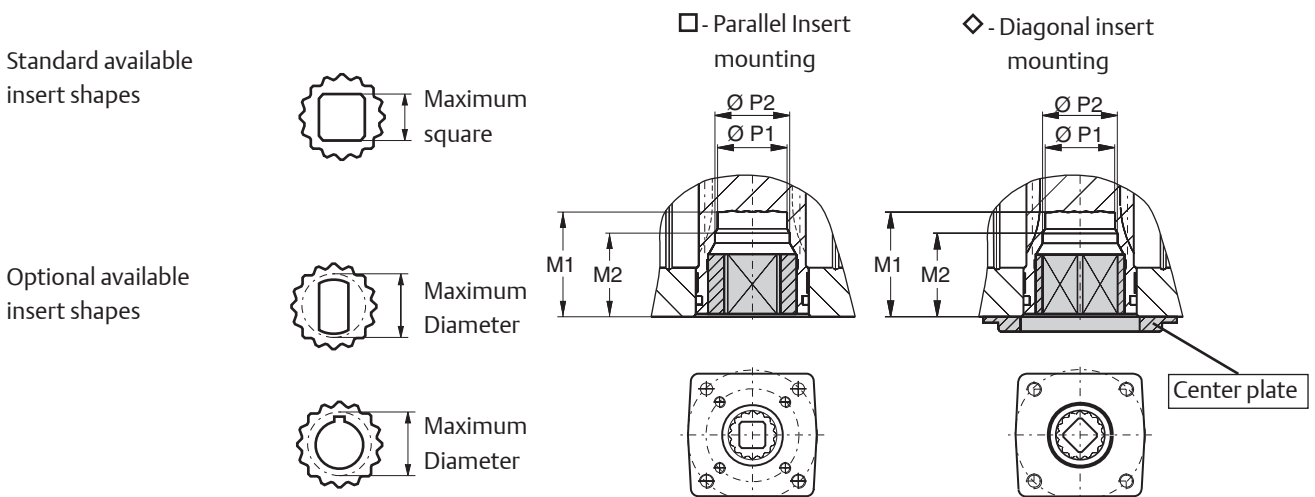
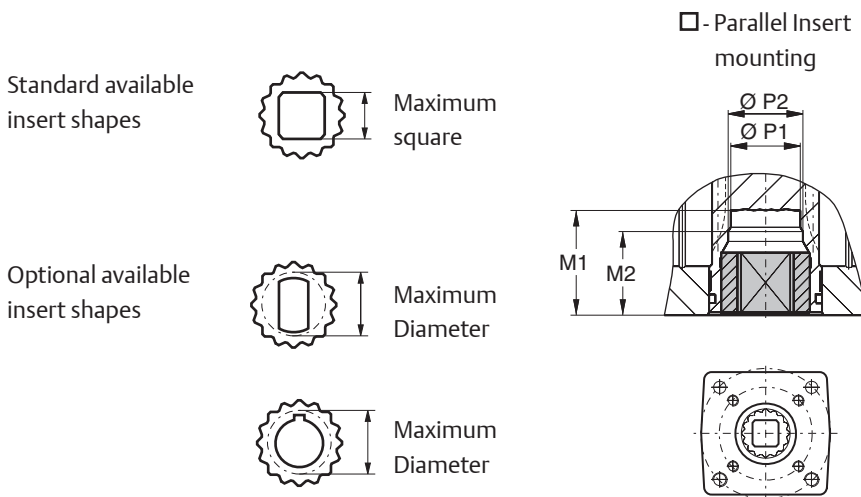

Table 4. Imperial drive square overview

Dim. in inches	25	0040/ 0065	100	150	200	350	600	950	1600	2500	4000
Standard square drive dimensions											
Type	Insert	Insert	Insert	Insert	Insert	Insert	Insert	Insert	Insert	Insert	Star drive
Parallel ■	0.433	0.551	0.748	0.748	0.866	1.063	1.063	1.417	1.811	1.811	2.165
Diagonal ◆	0.433	0.551	0.669	0.669	0.866	0.866	1.063	1.417	1.811	1.811	2.165
Optional square insert dimensions (Notes 1)											
	0.315	0.315	0.354	0.354	0.354	0.354	0.354	0.551	0.866	0.866	No insert
	0.354	0.354	0.394	0.394	0.394	0.394	0.394	0.748	1.063	1.063	
	0.394	0.394	0.433	0.433	0.433	0.433	0.433	0.866	1.181	1.181	
		0.433	0.472	0.472	0.472	0.472	0.472	1.063	1.417	1.417	
		0.472	0.551	0.551	0.551	0.551	0.551	1.181			
		0.630	0.630	0.630	0.630	0.630	0.630				
				0.866	0.669	0.669	0.669				
				0.945	0.748	0.748	0.748				
				0.984	0.945	0.945	0.866				
				1.063	0.984	0.984	0.945				
					1.063		0.984				
Maximum adaptor/valve stem dimensions											
M1	1.358	1.358	1.358	1.969	1.969	1.969	2.047	2.539	3.189	3.189	No insert
M2	-	-	27.5	-	37	37	-	-	-	-	
P1	0.555	0.717/ 0.835	0.925	1.122	1.268	1.268	1.449	1.902	2.37	2.37	
P2	-	-	0.992	-	1.429	1.429	-	-	-	-	
Sq. max.	0.433	0.630	0.748	1.063	1.063	1.063	1.063	1.417	1.811	1.811	
D max.	0.543	0.827	0.929	1.323	1.323	1.323	1.323	1.772	2.362	2.362	

1. Above table shows an overview of the default insert sizes and the most common square shaped insert sizes. Please contact your local Bettis representative for all available insert sizes



Insert Removal tool

Description

The standard Bettis RPE-Series actuators are equipped with Square-Drive inserts according to ISO5211. When assembled at the factory, the inserts are press-fitted on an edge in the pinion bottom. In order to be able to replace these standard inserts, these insert removal tools will help you to easily remove the standard insert from the pinion bottom.

Availability

The insert removal tools are available in two versions and can be used up to actuator size 600. For larger actuator sizes, up to size 2500, it is recommended to use a generic pulley puller.

Intended use:

These insert removal tools are intended to be used just before the installation of the actuator onto a valve and where the default insert needs to be replaced by an insert with a different size or shape.

Operation:

The insert removal tools are equipped with 3 square bits that fit exactly in the insert square of the actuator. Make sure the square bits are as high as possible on the threaded rod. Then you can insert (1) and rotated 45° (2) the tool and one of the square bits will hook under the insert.

The knob (3) on the tool can now be rotated until the insert gets loose (4) and it can be removed from the pinion's bottom.

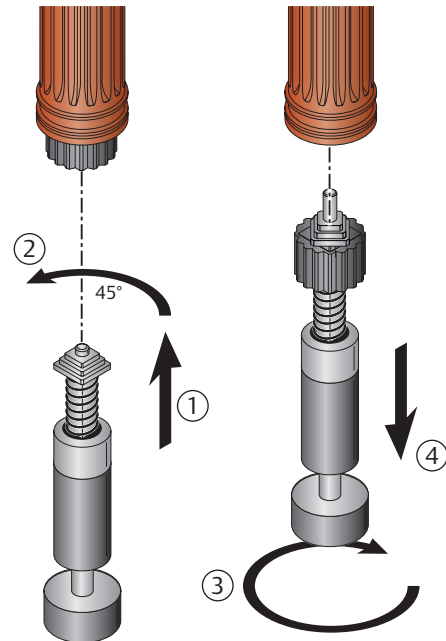

Specifications:

Tool part nr.:	Squares:	Actuator sizes:
VA590.00.001	11, 14 and 17	25, 40, 65, 100, 150
VA590.00.002	19, 22 and 27	100, 150 200, 350, 600

Materials:

Body, Knob and bits: Carbon steel, Zinc Plated

Center Plate / Center ring

Key features

- Durable design allows good alignment of actuator and valve.
- Prevents wear on valve spindle or mounting kit due to misalignment.
- Center plates can easily be added to standard actuator.
- Most actuators are available with two center plates for flexible valve mounting.
- Equipped with slot to release pressure, trapped between valve and actuator.

Description:

Bettis RPE Series actuators can be equipped with a center plate which takes care that actuator and valve (or valve mounting kit) are aligned when mounted. For most of the actuator sizes two centering plates are available. Size 4000 is available with a stainless steel center ring in a machined groove in the valve flange.

Specifications:

- Material plate: Nylon PA6, Black
- Material ring: Stainless Steel (Size 4000 only)

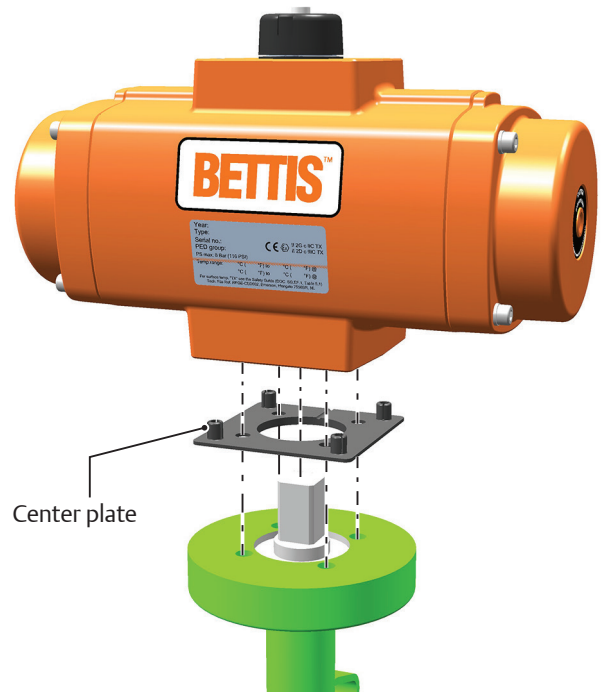

Bettis RPE Series actuator models ⁽¹⁾

	0025	0040	0065	0100	0150	0200	0350	0600	0950	1600	2500	4000 ⁽²⁾
Default ⁽¹⁾	F05	F05	F05	F07	F07	F10	F10	F12	F14	F16	F16	F25
Option	-/-	F07	F07	F05	F10	F07	F07	F10	-/-	-/-	-/-	-/-

Notes:

1. Default selection if actuator needs to comply to DIN 3337, see dimension sheet BED.04.01.EN.
2. Size 4000 is available with a stainless steel center ring in a machined groove in the valve flange.

Visual indicator Bettis RPE-Series actuators

Description

Bettis RPE-Series actuators have a large visual position indicator which allows clear indication of the valve's position at almost any position.

Bettis RPE-Series indicator is designed for position indication of actuators mounted "in line" with the pipe line and mounted "cross line" with the pipe line.

Conversion is easily done by turning the indicator 90° and reassemble back in place.

By default, the position indicator will be mounted "in line".

Specifications:

Materials:

- Indicator knob: ABS, Black
- Indicator arrow: ABS, White
- Indicator screw: SS Head cap screw M6x12

Center piece of large indicator.

The large indicator, for sizes 600-4000, is designed with a press fitting onto the pinion top. This way, the indicator will stay also on the pinion top without the indicator screw fitted. This press fitting feature together with the option to punch out the center piece of the vane of the large indicator, offers a passageway for a switch box or positioner shaft, up to a diameter of 20mm (0.787").

Ø 20mm (0.787")



Punched out center piece



Indicator mounting "In-line"

Size 12 - 350

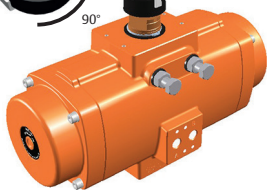
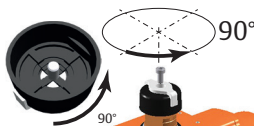
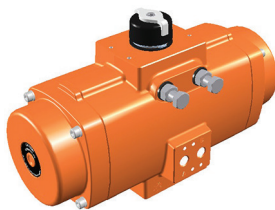

Size 600 - 4000

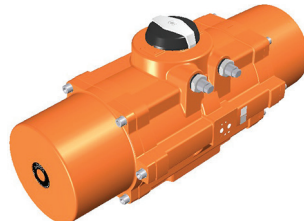

90°

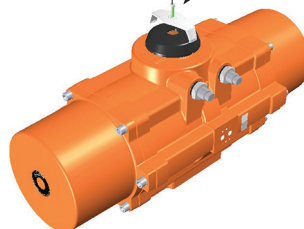

Indicator mounting "Across Line"

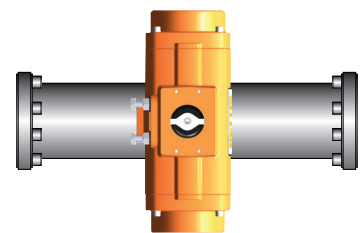
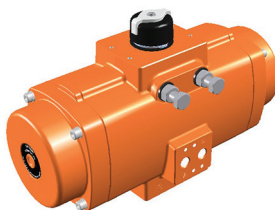

High Temperature Execution

Description

A double piston, rack and pinion pneumatic actuator, incorporating an anti-blowout pinion and a piston support system with high duty synthetic bearings at all bearing points.

This version is a standard aluminum actuator, but incorporating grease, O-ring seal and bearing materials, suitable for high temperature operation up to 250°F (120°C).

Specification

Max. pressure: 120 psig (8 barg)
Torque: Standard
Media: Air or non corrosive gas
Temperature: 14°F to +250°F (-10°C to +120°C)
Finish: Polyurethane powder coating
(see data sheet BRG.01.03.EN)

Spare parts

Dedicated high temperature spare part kits are available for maintenance or to convert a standard actuator in to a version suitable for high temperature operation.

High temperature components:
- Castrol High temperature grease
- Viton (FPM) O-ring seals
- PTFE 25% carbon filled piston bearings
- Nylon 66 resin containing Aramid Fibre & PTFE for bearing strip piston rack and pinion bearings.

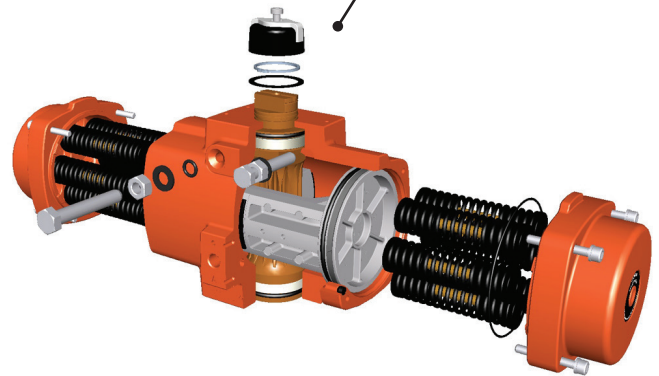

Description	Material
House	Cast Aluminium alloy
End cap	Cast Aluminium alloy
Piston	Cast Aluminium alloy
Pinion	High grade aluminium
Spring cartridge	Spring steel
Bearing strip piston rack	Nylon 66 resin containing Aramid Fibre & PTFE
Bearing piston	PTFE 25% carbon filled
Bearing pinion	Nylon 66 resin containing Aramid Fibre & PTFE
Thrust washer	POM, black UV stabilized
End cap screw	Stainless Steel
Circlip	Spring steel
O-ring seal pinion	Viton FPM
O-ring seal piston	Viton FPM
O-ring seal end cap	Viton FPM
O-ring seal limit stop	Viton FPM
B-port seal	Silicon rubber
Limit stop screw	Stainless steel
Limit stop nut	Stainless steel
Limit stop washer	PA66
Warning sticker	Polyester
Indicator assembly	ABS + stainless steel screw
Center plate (option)	Nylon PA6, Black
Insert drive	Aluminium alloy
Grease	Castrol High temperature grease

Low Temperature Execution

Description

A double piston, rack and pinion pneumatic actuator, incorporating an anti-blowout pinion and a piston support system with high duty synthetic bearings at all bearing points.

This version is a standard aluminum actuator, but incorporating grease and O-ring seal materials, suitable for low temperature operation down to -40°F (-40°C).

Note:

When operating actuators in sub-zero temperatures (< 0°C or < 32°F) care should be taken to counter the effects of freezing condensate inside the actuator.

Specification

Max. pressure:	120 psig (8 barg)
Torque:	Standard
Media:	Air or non corrosive gas
Temperature:	-40°C to +80°C (-40°F to +176°F)
Finish:	Polyurethane powder coating (see data sheet BRG.01.03.EN)
Cycle life:	Replace the seals after 250.000 cycles

Spare parts

Dedicated low temperature spare part kits are available for maintenance or to convert a standard actuator in to a version suitable for low temperature operation.

Low temperature components:
- Castrol Tribol GR TT 1 PD grease
- Silicone (MVQ70 rubber) O-ring seals

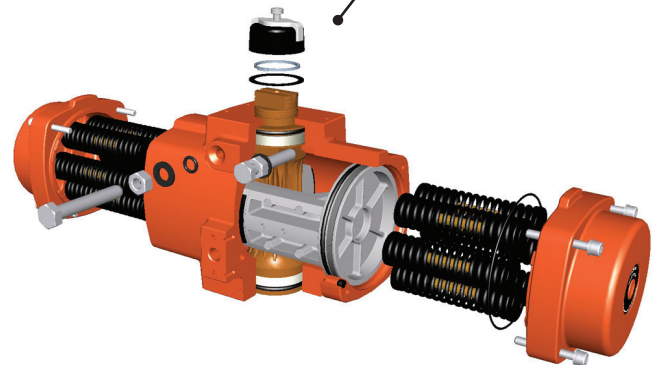

Description	Material
House	Cast Aluminium alloy
End cap	Cast Aluminium alloy
Piston	Cast Aluminium alloy
Pinion	High grade aluminium
Spring cartridge	Spring steel
Bearing strip piston rack	POM
Bearing piston	PTFE 25% carbon filled
Bearing pinion	POM
Thrust washer	POM, black UV stabilized
End cap screw	Stainless Steel
Circlip	Spring steel
O-ring seal pinion	Silicone MVQ70
O-ring seal piston	Silicone MVQ70
O-ring seal end cap	Silicone MVQ70
O-ring seal limit stop	Silicone MVQ70
B-port seal	Silicon rubber
Limit stop screw	Stainless steel
Limit stop nut	Stainless steel
Limit stop washer	PA66
Warning sticker	Polyester
Indicator assembly	ABS + stainless steel screw
Center plate (option)	Nylon PA6, Black
Insert drive	Aluminium alloy
Grease	Castrol Tribol GR TT 1 PD grease

Bettis RPE-Series with Stainless Steel pinion

AISI 316 Stainless Steel Pinion + Fasteners (A4-70)

Key features

- Extended corrosion resistant properties for applications where the standard pinion material is not sufficient.
- AISI 316 grade stainless steel pinion material.
- A4-70 grade stainless steel fasteners.
- Available with parallel and diagonal square drive for ISO5211 or DIN3337 valve mounting.
- Typically suitable for areas where standard aluminum pinions fail prematurely due to heavy corrosion, for instance protected areas on off-shore platforms.

Coating:

Polyurethane powder coating for exterior use (= default coating).

Pinion:

Stainless steel
AISI 316

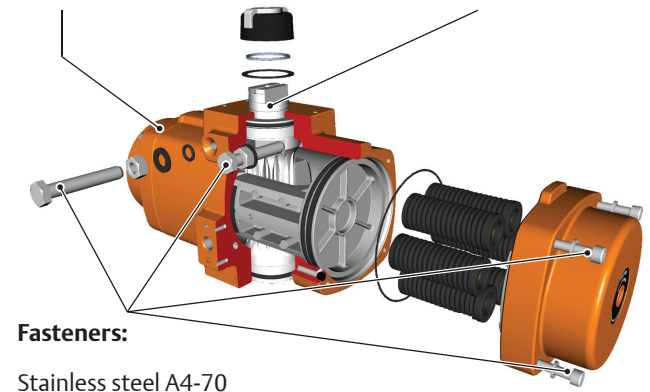

Description

Bettis RPE-Series with AISI 316 stainless steel pinion and fasteners (A4-70) offers an extended corrosion resistance in environments where standard actuators with aluminium pinions might fail prematurely due to higher corrosion levels..

AISI 316 grade stainless steel

Stainless steel 316 has excellent corrosion resistance when exposed to a range of corrosive environments and media. It is usually regarded as “marine grade” stainless steel. As such actuator with stainless steel pinions and fasteners can be used in near sea shore plants or protected areas on off-shore platforms.

Technical data:

Coating:	Polyurethane powder coating for exterior use (= default coating).
Color:	Bettis Orange (RAL 2009)
Corrosion resistance:	1500hr, ASTM B117
Max. Temperature:	-20° to + 80°C (-4°F to +176°F)
Materials Housing:	Aluminum alloy, anodized
Pinion:	Stainless Steel AISI 316
Fasteners:	Stainless steel A4-70
Type Sticker:	Polyester
Application:	Optional on Bettis RPE-Series actuators.
Dimensions:	See page 2

Dimension for Bettis RPE-Series actuators with Stainless Steel pinions.

Bettis RPE-Series actuators with the stainless steel pinions are not suitable for the use of drive inserts. The pinions of these actuators are fitted with 2 drive squares (rotated at 45°) in the pinion bottom. These drive squares are according ISO5211. All the other actuator dimensions are the same. Please refer to:

- BEM.04.01.EN for Metric ISO units
- BED.04.01.EN for Metric DIN units (with center plate)
- BEI.04.01.EN for Imperial ISO units

For the drive square dimensions of the stainless steel pinions, see below drawing and table.

Dim. in mm	Drive square dimensions Stainless Steel pinions											
	25	40	65	100	150	200	350	600	950	1600	2500	4000
S1 Max.	11.08	14.08	14.08	19.13	22.11	22.11	27.11	27.11	36.16	46.16	46.16	55.19
S1 Min.	11.00	14.00	14.00	19.00	22.00	22.00	27.00	27.00	36.00	46.00	46.00	55.00
S2^{+0.5}	14.4	18.5	18.5	22.5	22.5	28.5	36.5	36.5	48.2	60.2	60.2	72.2
S3	17	17	17	20	28	28	30	31	40.5	53.5	53.5	61.5
S4	27	27	27	27	40	40	38	38	50.5	65.5	65.5	76.5
S5	15	19	19	23	23	29	37	37	48.8	60.8	60.8	72.8

Dim. in inch	Drive square dimensions Stainless Steel pinions											
	25	40	65	100	150	200	350	600	950	1600	2500	4000
S1 Max.	0.436	0.554	0.554	0.753	0.870	0.870	1.067	1.067	1.424	1.817	1.817	2.173
S1 Min.	0.433	0.551	0.551	0.748	0.866	0.866	1.063	1.063	1.417	1.811	1.811	2.165
S2^{+0.02}	0.57	0.73	0.73	0.89	0.89	1.12	1.44	1.44	1.90	2.37	2.37	2.84
S3	0.67	0.67	0.67	0.79	1.1	1.1	1.18	1.22	1.59	2.11	2.11	2.42
S4	1.06	1.06	1.06	1.06	1.57	1.57	1.50	1.50	1.99	2.58	2.58	3.01
S5	0.59	0.75	0.75	0.91	0.91	1.14	1.46	1.46	1.92	2.39	2.39	2.87

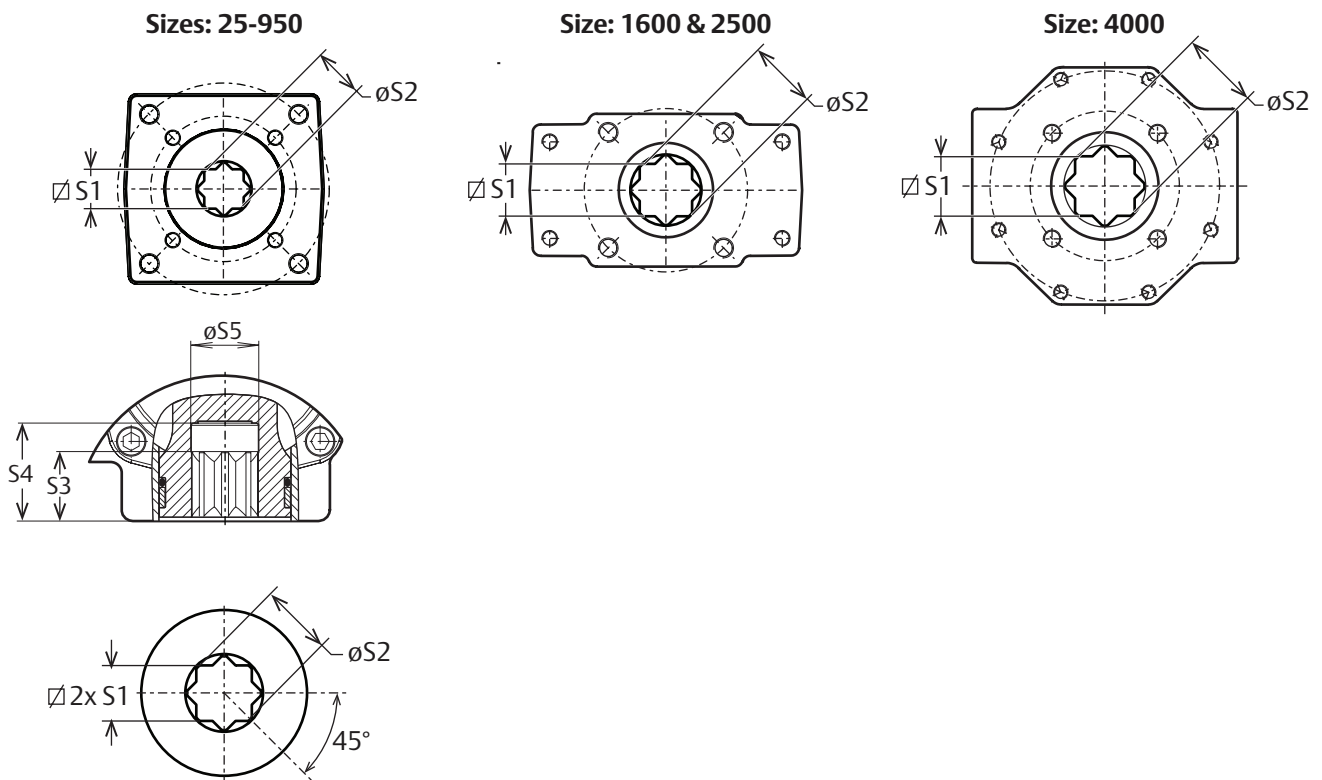

Actuator Operating Media Specification

For use with natural gas

Description

The standard Bettis RPE-Series actuator can be operated with natural gas. The natural gas should be qualified as "Sweet" and "Dry" (a.k.a. "Pipeline quality").

"Sweet" natural gas:

- Contains < 2 volume % of CO₂
- Contains < 1 volume % of H₂S

If the natural gas contains more than 2 volume % of CO₂ and more than 1 volume % of H₂S it is regarded as Sour Natural Gas and is not suitable as operating medium for the standard RPE-Series actuator.

"Dry" natural gas:

The natural gas should be as dry as possible. The recommended pressure dew point of the natural gas should be at least 10°C less than the lowest ambient temperature expected.

NOTE:

1. Care should be taken that fittings, tubing and controlling valves are also compatible to the media.
2. Natural gas is according Pressure Equipment Directive (PED) 2014/68/EU rated as a Group 1 gas (flammable, explosive or poisonous gasses). A limited range of the standard Bettis RPE Series actuator sizes are suitable for PED Group 1 gasses. For use in the European Union special product labeling is required and available.

Bettis RPE-Series

The standard aluminium actuator, is utilizing materials which overcome the problems associated with the use of natural (sweet) gas as an operating media, these are:

1. Sulfide stress cracking of metallic parts
2. The chemical attack by hydrogen sulfide and organic sulphur compounds.
3. No brass or bronze components.

Warning:

- Natural gas is a flammable, explosive and poisonous gas.
- Take appropriate measures to prevent ignition and poisoning during installation, commissioning and operation, according local or national law.

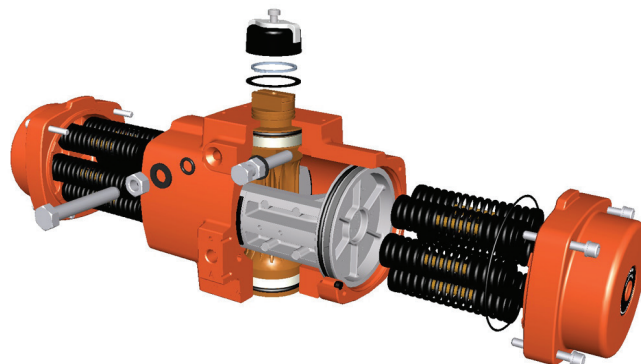

General specifications:

Pressure:	8.3 bar max. (120 psi)
Torque:	Standard, see data sheet(s)
Spring return:	Nm: BEM.03.01.EN Lbf.in: BEI.03.01.EN
Double acting:	Nm: BEG.03.02.EN Lbf.in: BEG.03.02.EN
Dimensions:	See data sheets: Imperial ISO5211 BEI.04.01.EN Metric ISO5211 BEM.04.01.EN Metric DIN3337 BED.04.01.EN
Operating Media:	"Sweet" and "Dry" natural gas (a.k.a. "Pipeline quality")
Dew Point:	At least 10°C less than the lowest ambient temperature expected.
Coating :	Polyurethane powder coating for exterior use.
Salt spray test :	ASTM B117: 1500 hours
Color :	Orange (RAL 2009)
Materials:	Housing: Anodized aluminium alloy Endcaps: Anodized aluminium alloy Pistons: Chromated aluminium alloy Pinion: High grade aluminium alloy, hard anodized.
Fasteners:	Stainless steel or alloy steel with Deltatone® treatment
Type Sticker:	Polyester

Fast Cycling RPE-Series actuators

Increase the cycle speed of actuators

Cycle speed:

In general pneumatic Bettis RPE-Series actuators are equipped with large internal air porting that allows adequate cycling under normal circumstances and when using generic solenoid valves to operate the actuator, the achieved cycle speed is normally sufficient.

In order to increase the cycle speed of the Bettis RPE-Series two options are available:

- High Flow plates
- Actuators with 1/2" air connection porting (only available for sizes RPE 950 to RPE 4000)

High Flow plates on Standard actuators

If faster cycle times are required (<0.5 or <1 second), 1/4" solenoid valves or pneumatic fitting material can become a problem. These components will then function as a throttle, reducing the potential maximum air flow and as such the limiting the maximum cycle speed.

In order to use the maximum cycle speed potential of a standard actuator, the 1/2" High Flow adaptor plate allows the fitting of larger solenoid valves and pneumatic fitting material and as such the increase the maximum cycle speed.

Construction:

The High Flow Plate is a aluminum plate which can be mounted directly to solenoid interface on actuators which are designed according VDI/VDE 3845 (NAMUR). The plate is supplied with fasteners and seals.

The customer side of the plate is equipped with one larger 1/2" NPT or BSP air connection (A-port) for piped solenoid control.

Materials:

- Block: Aluminium alloy, black anodized (10-15µm)
- Fasteners: Stainless steel
- O-ring seals: NBR Rubber

Table 1. High Flow plates

Part nr:	Execution:
VA306.00.310	1/2" NPT
VA306.00.320	1/2" BSP

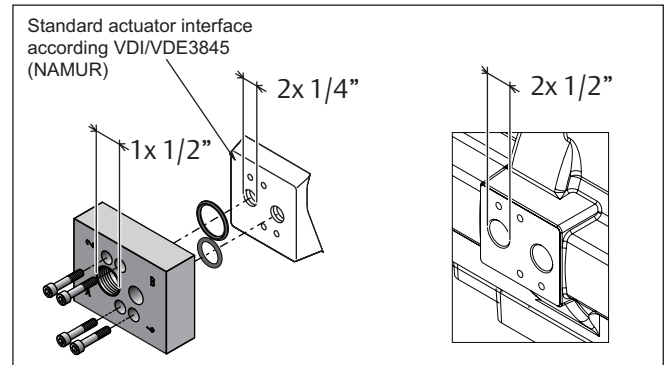

Actuators with 1/2" air connection porting.

In order to increase the cycle speed of actuator of the larger sizes RPE950 to RPE4000, these actuators are available with 1/2" BSP or NPT air connections for both the A and B port and comply with the 1/2" pneumatic connection specification of EN15714-3.

Additionally the internal air channels of the housing are larger than on the standard housing. Together with the mounting of 1/2" solenoid and or quick exhaust this allows very fast cycle speeds.

Maximum cycle speed

In order to select the correct actuator configuration, please find below a table of maximum cycle speeds that can be achieved for the standard 1/4" ported houses and the optional 1/2" ported houses.

1. For practical considerations follow the next recommendations.
2. Consult the nearest Bettis representative or Emerson office for technical support.

Table 2. Maximum cycle speeds (seconds)

Actuator size	House with 1/4" ports	House with 1/2" ports
12	0.4	Not available
25	0.4	Not available
40	0.5	Not available
65	0.6	Not available
100	0.7	Not available
150	0.8	Not available
200	1.0	Not available
350	1.5	Not available
600	2.2	Not available
950	2.5	0.8
1600	3.3	1.2
2500	5.4	1.7
4000	10.7	3.2

Test conditions:

Solenoid with flow capacity:

- Up to size 600	0.6 m ³ /hr	Not available
- 950 and larger	1.45 m ³ /hr	2.49 m ³ /hr

Pipe diameter:

- Up to size 600	6 mm	Not available
- 950 and larger	10 mm	12 mm

Medium: Clean air

Supply pressure: 5.5 bar/80psi

Load: With average load

Stroke: 90°

Temperature: Room temperature

Notes:

Faster stroking speeds are available but may require special design. If faster stroking speeds are required contact the engineering department.

Recommendations:

- The High Flow Plate or the 1/2" ported housing on its own do not make the cycle time of an actuator faster. Take care that there is sufficient air supply capacity at actuator:
 - Air supply capacity must be larger than the Cv or Kv value of the control solenoid valve.
 - Use tubing with sufficient large diameter.
 - Make tubing from the main air supply to the actuator as short as possible.
- Consider the use of Quick Exhaust valves in combination with High Flow Plate or the 1/2" ported housing.
- In general the actuators life cycle is reduced when cycling very fast.

Table 3. Port dimension options RPE950 to RPE4000

Dim	Metric Units		Imperial Units	
	1/4"	1/2"	1/4"	1/2"
S	1/4" BSP	1/2" BSP	1/4" NPT	1/2" NPT
S1	32	45	1.26"	1.77"
S2	24	40	0.94"	1.57"
S3	M5x8	M6x10	UNC 10-24 x 0.31"	1/4"UNC x 0.39"

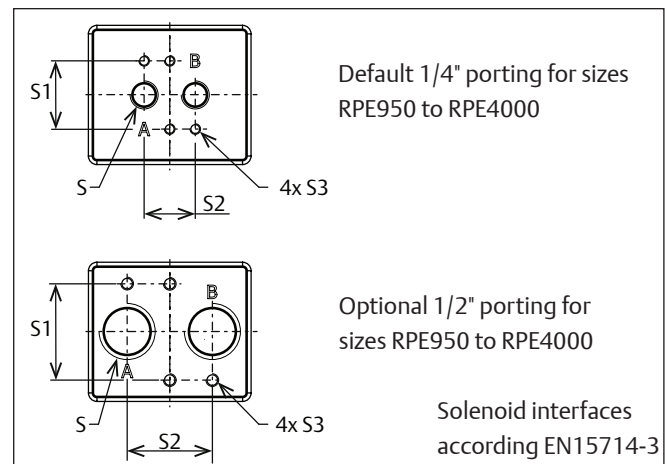
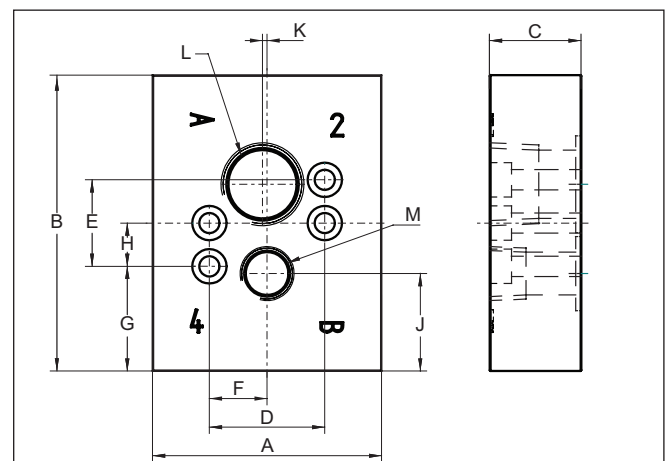

Table 4. High Flow Plate Dimensions:

Dimension in:	mm	Inch
A	63.5	2.50
B	82	3.23
C	25.4	1.00
D	32	1.26
E	25	0.98
F	16	0.63
G	29	1.14
H	12	0.47
J	27	1.06
K	1.27	0.05
L	1/2" BSP	1/2" NPT
M	1/4" BSP	1/4" NPT



www.globalsupplyline.com.au

Global Supply Line are Bettis resellers and stockists. We are an approved Emerson Actuator distributor.

We can supply/ quote complete actuator packages for emergency supply within Australia, New Zealand, Papua New Guinea and all overseas locations from our Adelaide Emerson Approved Automation Centre. [Click here](#) for our full on line stock list.