

## RING NUMBERS AND SIZES CHART FOR RING JOINT FLANGES

All dimensions are in inches.

Regularly listed flanges, except Lap Joint, can be furnished with Ring Joint facing. Flanges with Octagonal groove will be supplied. Since Oval groove are no longer standard. Either Oval or Octagonal rings can be used with flanges having Octagonal grooves.

"X" column shows approximate distance between faces of two Ring Joint flanges when ring is compressed.

1. The dimension of the rings and grooves of Ring Joint flanges rated at 300, 400 and 600LBs are identical.
2. Raised face 'L' is equal to the groove dimension 'E' but is not subject to the tolerance for 'E'.
3. Depth of groove is added to the minimum flange thickness. The maximum corner radius 'r' is 1/32" for groove widths of 15/32" and smaller, 1/16" for groove widths from 17/32" through 29/32" and 3/32" for groove widths larger than 1".

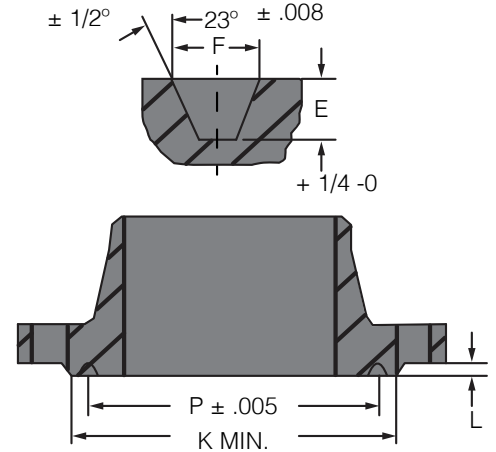

Ring Number	Pitch Diam. P	Width of Groove F	Depth of Groove E (2) (3)	150 LB		300 LB - 400 LB - 600 LB			1500LB		2500 LB		
				Raised Face Diam. K	Space Between Flanges X	Raised Face Diam. K	Space Between Flanges X			Raised Face Diam. K	Space Between Flanges X	Raised Face Diam. K	Space Between Flanges X
							300 LB	400 LB	600 LB				
R11	1 11/32	9/32	7/32			2	1/8		1/8				
R12	1 9/16	11/32	1/4							2 3/8	5/32		
R13	1 11/16	11/32	1/4			2 1/2	5/32					2 9/16 5/32	
R14	1 3/4	11/32	1/4							2 5/8	5/32		
R15	1 7/8	11/32	1/4	2 1/2	5/32								
R16	2	11/32	1/4			2 3/4	5/32		5/32	2 13/16	5/32	2 7/8 5/32	
R17	2 1/4	11/32	1/4	2 7/8	5/32								
R18	2 3/8	11/32	1/4			3 1/8	5/32		5/32	3 3/16	5/32	3 1/4 5/32	
R19	2 9/16	1 1/32	1/4	3 1/4	5/32								
R20	2 11/16	11/32	1/4			3 9/16	5/32		5/32	3 5/8	5/32		
R21	2 27/32	1 5/32	5/16									4 1/8	
R22	3 1/4	11/32	1/4	4	5/32								
R23	3 1/4	15/32	5/16			4 1/4	7/32		3/16			4 1/2 1/8	
R24	3 3/4	15/32	5/16							4 7/8	1/8		
R25	4	11/32	1/4	4 3/4	5/32								
R26	4	15/32	5/16			5	7/32		3/16			5 1/4 1/8	
R27	4 1/4	15/32	5/16							5 3/8	1/8		
R28	4 3/8	17/32	3/8									5 7/8 1/8	
R29	4 1/2	11/32	1/4	5 1/4	5/32								

Nominal Pipe Size	1/2	3/4	1	1 1/4	1 1/2	2	2 1/2	3	3 1/2	4
150 LB			R15	R17	R19	R22	R25	R29	R33	R36
300 LB 400 LB 600 LB	R11	R13	R16	R18	R20	R23	R26	R31	R34	R347
900 LB								R31		R37
1500 LB	R12	R14	R16	R18	R20	R24	R27	R35		R39
2500 LB	R13	R16	R18	R21	R23	R26	R28	R32		R38

Nominal Pipe Size	5	6	8	10	12	14	16	18	20	24
150 LB	R40	R43	R48	R52	R56	R59	R64	R68	R72	R76
300 LB 400 LB 600 LB	R41	R45	R49	R53	R57	R61	R65	R69	R73	R77
900 LB	R41	R45	R49	R53	R57	R62	R66	R70	R74	R78
1500 LB	R44	R46	R50	R54	R58	R63	R67	R71	R75	R79
2500 LB	R42	R47	R51	R55	R60					